



# **SOLAR PRODUCTS INC.**

## **THE INFRARED HEATER COMPANY**

# **THERMOFORMING EQUIPMENT RETROFIT GUIDEBOOK**

A complete guide to upgrading your system for  
better productivity and increased profits



# THERMOFORMING EQUIPMENT RETROFIT GUIDEBOOK

## Second Edition

### INTRODUCTION

The age-old question that always comes up when addressing your thermoforming equipment needs is: what to do with that old equipment. "To retrofit or not," that is the question. Should you purchase a new machine with all those bells and whistles? Should you purchase a used machine? Or should you rework that unit that is hanging on by the last thread? The decision depends on what your needs are today and what you expect them to be in the future. Is the platen or clamp frame size large enough for the products that you expect or want to produce or generating too much labor overtime?

Are your molds so large, and your zoning so inaccurate that the edges of the polyethylene will not heat up enough, and the center is drooping so low that it is dancing along the floor? These are just a few of the possible scenarios that should cause you to take a hard look at making changes in your thermoforming operation.

Undoubtedly, a new machine offers you many advantages over your present machine. But, do you want to spend \$50,000, \$200,000, or even \$400,000 for a new sheet-fed, rotary, or continuous machine? The answer, in many cases, is yes. You will note that a continuous machine will also be referred to as a roll-fed machine. The new machine may give you the speed required to keep up with your growing orders. It may give you the larger platen size you need to make that new line of whirlpool tubs. It may also give you the security of owning a new machine with a warranty, and a reduction in the many maintenance problems that your staff cannot handle now.

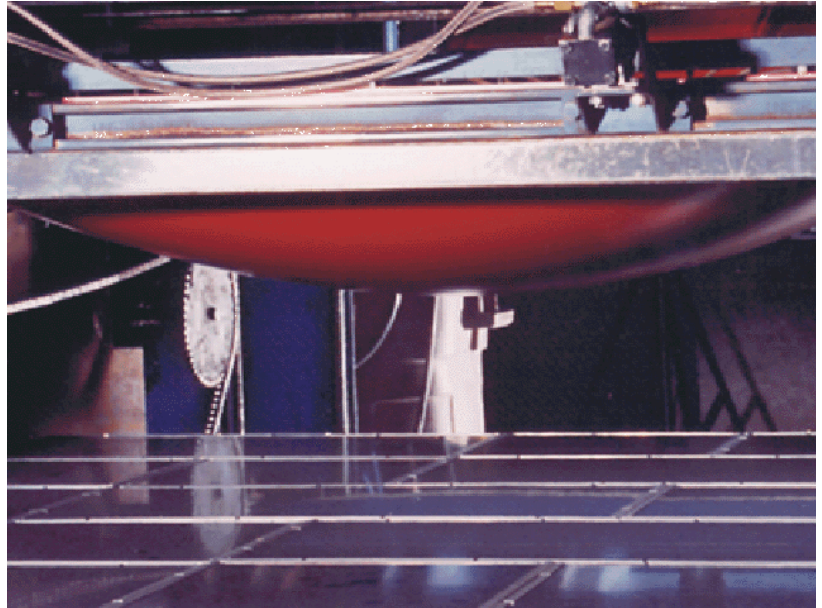

The used machine may look attractive in price compared to the new machine. But how many problems are you inheriting from the prior owner? Are you qualified in determining whether the machine is in tiptop working order? For example, are the motors ready to fail, the cylinder seal going to leak, the heaters about to quit heating? However, if you understand what you are purchasing, then a used machine can often be your best value.

Retrofitting your existing machine may seem to be a lot of work, cost, and headache. Will it really pay off? Or will all this talk about new controllers and heaters lead to improved product quality, decreased heating cycle, and improved bottom line?

Do you have the in-house mechanical support staff to pull off such an intimidating project, or do you need to turn to one of the many outside firms that specialize in retrofitting existing machines? Will your return on investment be worth all that hassle, and how do you determine what the return on investment will be?

As you can see, there are many questions but not many answers. If you still think that retrofitting is something worth mulling, please continue on.

# FIRST THINGS FIRST

**The most important item on your list is to contact your local utility.**

Many times, utilities have energy rebate programs that can assist in the payment of your retrofit. The rebate programs vary from utility to utility. The local industrial marketing representative is your best contact. Pacific Gas and Electric (PG&E) in California has an interesting rebate program, titled Customized Incentive Program. The program is set up to reward customers not only for lower peak kW but will additionally rebate for increased productivity. By lowering the peak demand, you can earn \$200 per kilowatt of reduction. On top of that, you can earn energy savings of 4 cents per kilowatt hour (kwh) of reduction for a one-year time period. That reduction in k-wh may be in the form of increased productivity. Increased productivity and lower energy costs are the two main benefits of performing a retrofit.

There are a few rules and guidelines that must be met in order to qualify for the program. You must be able to show a minimum \$2500 incentive in order to be eligible. There is also a limit to the amount paid by the utility. The maximum amount paid toward the retrofit costs is limited to 50% of the overall investment. The \$200 peak demand incentive is valid only if the peak is lowered during the hours between noon and 6 p.m., Monday through Friday, May 1 through October 31. The retrofit costs include the materials and outside labor costs. Sales tax, freight or delivery charges, in-house labor, project design, feasibility studies, and other indirect costs are excluded from the retrofit costs.

The Connecticut light and Power Company has a simple formula for quickly determining whether or not your retrofit is eligible for their Customer initiated program. in this formula, cost effectiveness is equal to:

$$\frac{\text{cost of retrofit}}{\text{kilowatt-hour savings per year x utility factor for the life of equipment}} \times 100 \text{ cents}/\$$$

## AN EXAMPLE

Let's say the productivity is increased by 75%, and the daily use (8 hour) of power (kwh), both before and year would be 250 days, 50 five-day weeks, multiplied by 330 kwh = 82,500 total kwh. A 75% increase in productivity suggests that 5 days of work can now be done in 2.85 days (5 days/ 1.75 = 2.85 days). The actual kwh usage, as a result of the retrofit, is 82,500/1.75 = 47,142 kwh. This equates to a kwh savings of 82,500 - 47,142 = 35,358 kwh. The utility company assigns a factor of 10 for thermoforming equipment.

$$\frac{\$10000}{(35,358 \times 10)} \times 100 \text{ cents} / \$ = 2.8 \text{ cents}$$

The utility wants this cost effectiveness member to be below 3.5 cents for approval into the program: In this case, the retrofit will most likely be a match for the Customer Initiated Program.

It is also important to review both the demand charge is calculated in your region. Most utilities suggest that the peak demand charge is averaged over a 15 or 30 minute time period. This can vary from utility to utility. Off peak rates can be considerably less expensive. For this reason, you may be better off operating early in the morning or later in die after noon to avoid the peak demand charge.

## IMPROVMENTS

The next item to be addressed is what components should be retrofitted. The most commonly changed items are the hearers and controls. We will spend most of our time reviewing the many heater and control options that arc available in today's market. There are a whole host of other items you may want to consider changing or may have to change. These items will also be touched upon.

## HEATER SELECTION

If you are at the point where you want to retrofit your thermoforming machine, chances are that the existing heaters are tubular metal sheathed heaters (Calrods). The vast majority of thermoforming units in the field have these tubular elements.

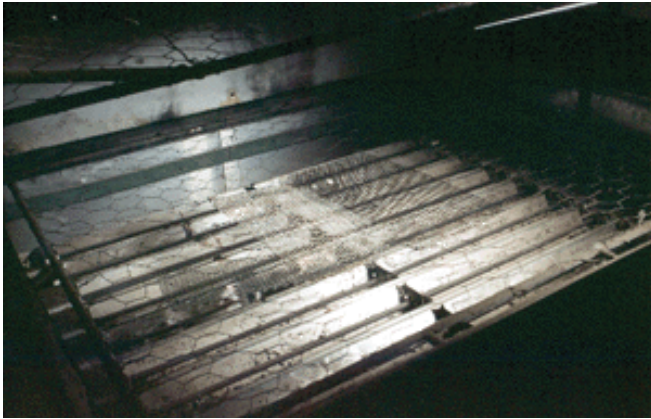

*Tubular Heaters*

The advantages of metal sheathed heaters are in the low initial cost and the durability. The biggest disadvantage is their inefficiency. The reason for approaching the retrofit is typically because of that low efficiency and the need for better zoning. The zoning should be accomplished through the heaters, not through screening. Today, there are many options other than metal sheathed heaters that provide that same durability, with improved zoning, and an efficiency that is greatly increased. There are many factors to consider in the selection of the proper heater for your needs. These factors are size, response, efficiency, price, installation, maintenance, uniformity, cost effectiveness, initial heat up time, heating cycle time, and durability.

All the electric heaters discussed in the heater section are medium or long wavelength. All the electric heaters can be either medium or long wavelength depending on where the temperature is set. The wavelength is inversely proportional to the temperature. By this we mean, as the temperature goes up, the corresponding wavelength goes down.

The gas catalytic heater is a long wavelength heater as described by the catalytic manufacturers. The minimum temperature of gas catalytic heaters is 750° F. By the infrared spectrum chart, this would still fall into the medium infrared category. Medium wave infrared is the most effective means of heating plastics.

Most plastics have two peaks on the absorption curve for the material. The first peak is at 3.5 microns and the second peak is between 6-10 microns. The absorption curve displays the infrared wavelengths that will best be absorbed by the plastic. Because the electric heaters can reach 3.5 microns, as well as the 6-10 micron they have a greater potential of heating the plastic in a shorter time period. All heaters have an output heating curve that carries over a certain temperature range. A heater that is set at 1100° F. (3.5 microns) will be delivering a peak percentage of energy at this temperature, but will actually deliver a range of temperatures and wavelengths. An infrared spectrum chart is shown:

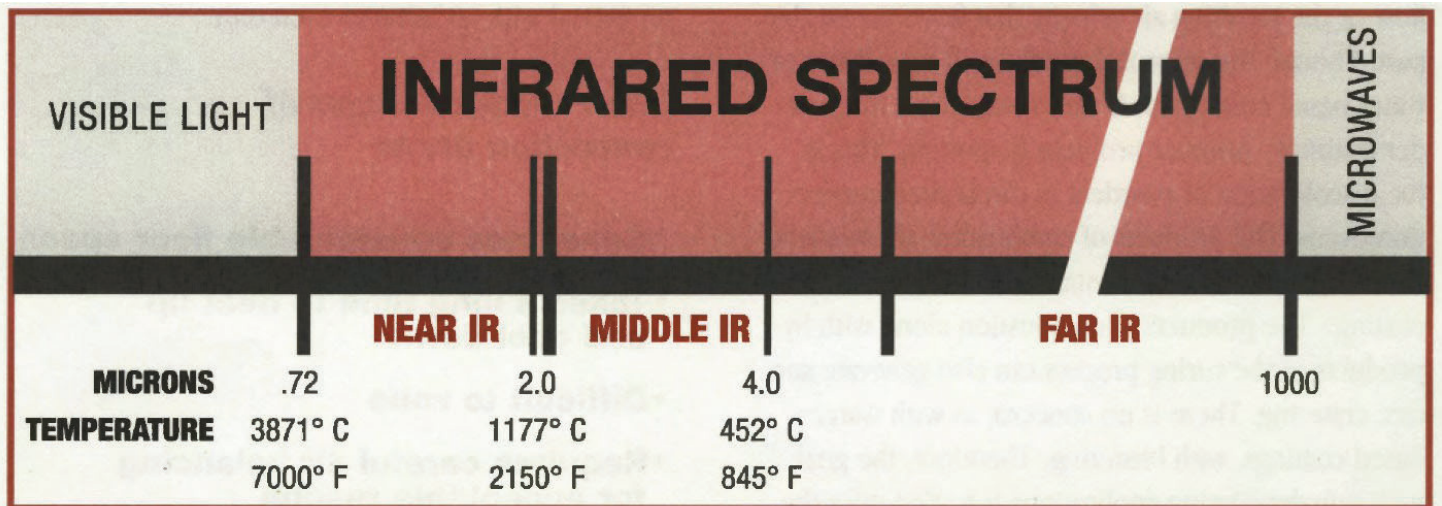

## SIZE AND CONFIGURATION

Size is a consideration based on the product as we discussed earlier. You may be operating a small sheet-fed machine that only runs one or two molds. The mold sizes are both approximately 18" X 12". In this case, one heater on the top may be sufficient. A second heater on the bottom would decrease the beating cycle time. The size of the heater could be 24" X 18" (Fig 1A).

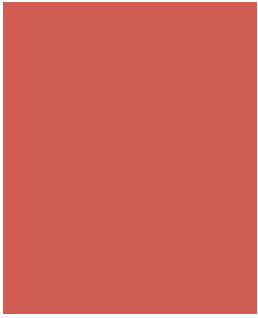

Figure 1A

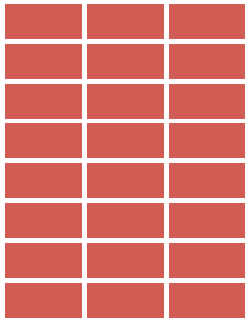

Figure 2A

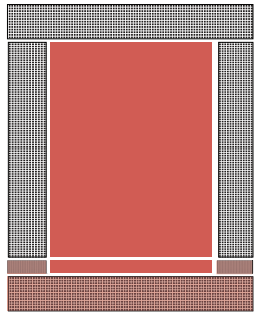

Figure 3A

Due to edge heat loss, the Heating area should always be larger than the mold. The size could also be (4) 3" X 18" and (1) 12" X 18" (Fig 1B). Another choice would be (24) 2.5" X 5" (Fig 1C). The mold size and zoning requirements for different size molds need to be carefully considered when choosing the size of the heaters.

Now, let's look at another application, such as a larger sheet feed or rotary machine. Many times there are several different molds used on a single machine. Sometimes, the different molds can be placed together on the platen to fill up the available area, but this is not always the case. If the maximum clamp frame size is 66" x 90", the overall heated area is 72" x 96", and the mold is only 30" x 24" or 36" x 48", you may want to have the flexibility of turning off the heaters around the outer edge or on one side. (See Figure 2). Having the ability to turn a large section of the oven area off for smaller molds, really saves a lot of energy over time.

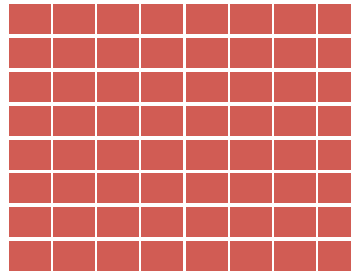

Figure 2A

Figure 2A makes use of (48) 12" x 12" heaters per oven half for complete zone control and flexibility. This many zones may also mean a 50% price premium for the heaters and controls.

Figure 2B makes use of (6) 12" x 48" and (12) 12" x 24" heaters.

Less zoning, but also less cost. This layout works fine for most applications.

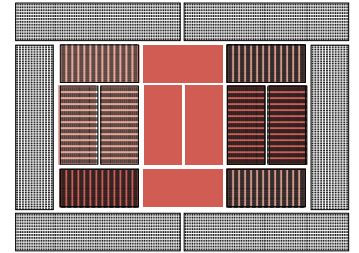

Figure 2B

Our final example is a roll-fed machine. A roll fed machine can be zoned in many different ways. The heaters can be placed in a row, perpendicular to the sheet direction, with multiple zones running down the sheet (center heaters Fig 3A). We can add to that a line of heaters along the long edge to help with edge heat loss. These heaters should be wired into a separate zone because the temperature will be raised to compensate for the extra heat loss along the edge. This edge heat loss zone is sometimes accomplished through the use of a single metal sheathed heater, running above the chain rail on each side, the entire length of the oven. Sometimes, pre-heat zones are added to the oven. These heaters are switched on/off to match the required index length of the oven to the mold size. More common, is a final heating zone that is perpendicular to the sheet direction just before the mold station. This heater operates at a little higher temperature due to the cooling effect that occurs from the molds opening and dosing. Because the center of the oven can sometimes get hotter than the outer edges, a last option would be to place those central main heaters parallel with the sheet (Figure 38). This will provide more consistent heating across the sheet by turning down the heat in the center and turning up the heat as the heaters proceed to the over edge. Most roll-fed machines will use a combination of these heater layouts. The heaters could be across the sheet for the top oven and running with the sheet direction on the bottom

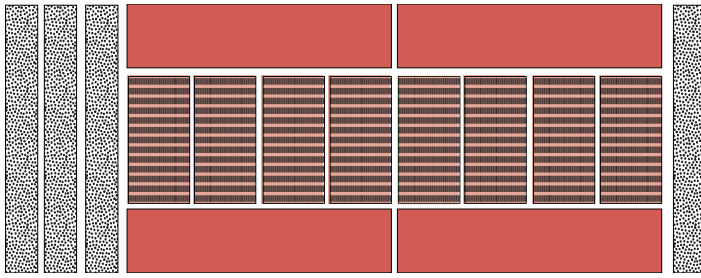

Figure 3A Top Oven

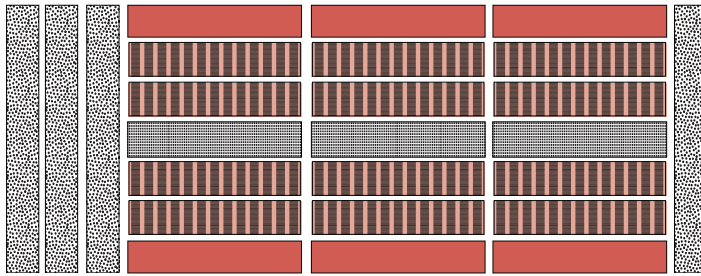

Figure 3B Bottom Oven

oven. As you can see, there are many options for positioning, sizing, and zoning of the heaters.

The key to choosing the proper size heater is right there in your own shop. How does the operation work with the existing heaters? How much watt density is in the existing oven and should it be increased? How are the zones presently arranged? How can this be improved upon? You probably already know the answers to these questions and can easily determine the best size and zone for the heaters.

## WHICH HEATER WOULD YOU SELECT FOR YOUR APPLICATION?

Several factors will determine which heater is the right choice for your site. Following is a list of the most commonly used heaters for retrofit.

### QUARTZ TUBE

If response time is the critical issue, then quartz tube heaters may be your best bet. Quartz tubes heat up and cool down very quickly (10 - 20 seconds) and are therefore very useful for a line that runs a few products and then shuts down for awhile. Consequently, selecting a quartz tube heater is the most cost-effective approach for a machine with long heater off cycles. On the flip side, quartz tubes can also be the highest installed cost for electric infrared heaters.

Quartz tubes are also fragile and can be easily broken, due to vibration or misuse. If a sheet falls onto bottom mounted quartz tubes, then the tubes will most likely be damaged beyond repair. Quartz tubes are used most often in sheet fed equipment. There are few cases where quartz tubes are used with in-line equipment. The small quartz tube fixtures sized the same as ceramic heaters have become more popular in the last year. These elements combine the zoning capability of small sizes along with the response and efficiency (due to the elements being shut down when not in use) of quartz tubes. The disadvantage is the initial cost of the elements and the high installation costs for many elements.

ELECTRIC HEATERS		GAS HEATERS	
<b>Panel Heaters</b>	<b>Quartz Tube</b>	<b>Ceramic</b>	<b>Catalytic</b>
Quartz cloth face - width: 3" - 30" length: 6" - 78"	Large quartz tube fixtures  Many size options	2.4" x 4.8"	width: 6" - 24" length: 6" - 36"
High Temperature glass face - width: 6" - 24" length: 6" - 36"	Small quartz tube fixtures	2.4" x 9.6"	
Metal Face - Same as quartz cloth.	2.4" x 4.8" and 2.4" x 9.6"	4.8" x 4.8"	



Tube Module

## CERAMIC HEATERS

Ceramic heaters offer considerable flexibility in zoning because of the small size of die elements. Their efficiency is in the middle of the available heaters. The price, for heaters only, is also in the middle. The installation is expensive due to mounting and wiring of many small heaters. The ceramic elements were designed in Germany in an effort to create a standard size element that could offer high efficiency, flexibility in zoning, interchangeability, long life, and uniformity from element to element. For the most part this has been accomplished. The reality for most thermoformers is that the need for such small zones is not required. In fact, many machine manufacturers that promote the use of ceramic elements do not zone each element individually. The elements are commonly zoned into 12" x 12" areas. With this said, ceramic elements are the heater of choice in most European applications and are used very extensively in the U.S. as well.

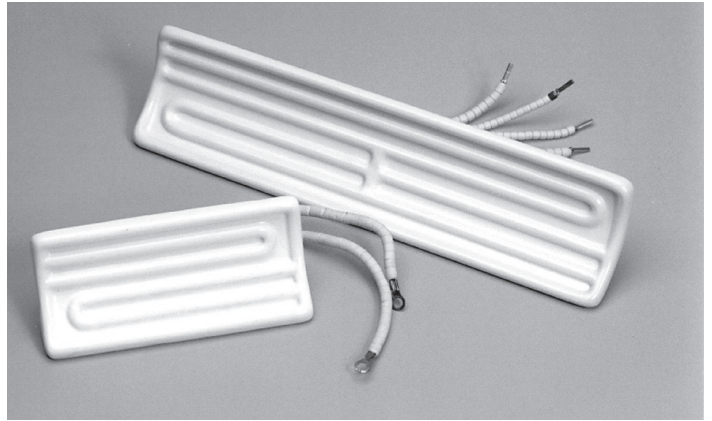

*Ceramic Heater*

range of 50% with gas catalytic heaters over metal sheathed electric heaters. But at the same time if the over length remains the same, the shots per minute can be reduced by 10 -25%, and the reject rate can be as high as 15% due to uneven heating of the sheet. It seems as though the zoning of the sheet and additional power in electric heaters is more of a requirement for continuous machines.

## GAS CATALYTIC HEATERS



*Gas Catalytic Heater*

Gas catalytic heaters are newer to the thermoforming marketplace, and there has been a lot of discussion claiming 70% reduction in energy costs as compared to electric heaters. That energy reduction of gas catalytic is actually in comparison to metal sheathed heaters, not the electric heaters commonly used for retrofits today. The gas catalytic heaters have primarily been used in single station and rotary sheet-fed applications. There is very little use of gas catalytic heaters in roll-fed machines. The retrofits that have been performed on those machines have shown energy reductions in the

Gas catalytic heaters operate based on a flameless. The reaction that occurs between the incoming gas, oxygen, and a catalyst material. The reaction generates heat. Because the typical maximum temperature of these heaters is 750° F., the heaters can be limited in their productivity increases and, in many cases, can actually extend the heating can be times when compared to existing Calrod heaters that are sized properly between 20 and 30 wsi for both the top and bottom oven, it seems as though the gas catalytic heaters work better with amorphous materials such as ABS where not as much power is required to heat the sheet. But for crystalline materials, such as HDPE, the gas catalytic heaters will have a considerably longer heating cycle time as compared to modern, efficient electric heaters. This is because the catalytic heaters are limited in power output. The electric heaters are not limited in power output for plastic applications. Another stated advantage of the catalytic heaters is the temperature uniformity across the heater. It is suggested that zoning is not required with these heaters due to the uniformity. Field experience shows that all ovens require zoning around the outer edge. Many parts require subtle zoning due to complexity of the dmw. Because catalytic heaters typically

use manual gas valves for control, it is difficult to set up the heaters when using a new mold. Scrap rates will be higher with catalytic heaters as a result of the control issue. A last consideration with gas catalytic heaters is the initial cost of the elements.

Typically, the cost of a gas catalytic retrofit is one and a half to two times as expensive as compared to a retrofit using modern, efficient electric heaters and controls. With all this said, there is no question that because gas costs are lower than electric costs across the country, gas catalytic heaters have their place in the world of thermoforming today.

---

***It is important; when deciding which heater to use, to look at the productivity, energy consumption, product quality, reject rates, heater and installation costs and the heater life expectancy, only when all of these considerations are taken into account, can the correct decision be made.***

---

## **PANEL HEATERS**

Following is a review of retrofit results from metal sheathed heaters compared 10 modern electric panel heaters. Because Solar Products is a manufacturer of panel heaters, the case study darn pertains to panel heater retrofits.

One example-of the success with panel heaters is a 5' x 5' two station sheet-fed operation using 1/8" and 3/16" AOS and HDPE. The initial power in the existing Calrod oven was low, namely 15 watts/sq in. (wsi) for the top and bottom oven. In This case, the productivity was increased by 75% on average and the energy consumption was reduced by over 50% when the increased productivity is taken into account. The reject rate of bad parts was virtually eliminated and the availability of machine time was increased by 12% due 10 increased productivity. There was a dramatic increase on profit due to lower production costs of manufactured parts. And the best part is that these figures will continue to hold true because there is no appreciable loss in energy efficiency over time with properly designed panel heaters.

If the original Calrod oven watt density is more properly sized, for the above example, between 20 and 30 wsi for the top and bottom oven, then we would see an increase in productivity between 10 to 30% over existing Calrod heaters with many different material types such as AOS, HOPE, styrene, PETG and so on. The power consumption is reduced by 25 - 40% without the increase in productivity taken into account. When the increase in productivity is taken into account, the energy savings is in excess of 40%. Therefore, panel heaters not only decrease the energy usage, but in addition, they increase the productivity. One customer broke down the power requirements on a per part basis. The power usage was reduced from 5.8 kw-hr per part with Calrods (properly sized in power output) down to 2.0 kw-hr per part with new panel heaters.

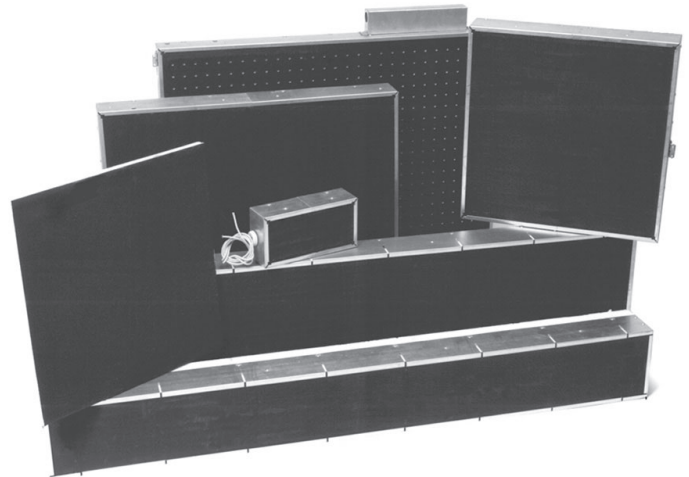

*Panel Heater*

---

***Therefore, panel heaters not only decrease the energy usage, but in addition they increase the productivity. The savings is a result of the panel heater radiant efficiency***

---

Roll-fed machine retrofits will display similar results as noted above for sheet-fed retrofits. In many cases, older roll-fed machines have the proper watt density of 30 wsi for the top and bottom oven and therefore we do not see huge increases in productivity. If the machine watt density is in the range of 15 wsi for top and bottom oven, then we would expect to see a big increase in line speed, while still reducing



the energy consumption up to 50%. This is assuming that nothing is blocking the increase in line speed. The productivity gains in continuous machines is more complex because of the many interfaces within the machine. The increase in line speed is dependent on the maximum speed of the trim press, and the mold station. Is there enough cooling in the mold for 111 increase in line speed? Is there enough cooling in the chain rails to pull the heat away? Is the mold designed properly for an increase in line speed? These items will help to decide if an increase in productivity is possible. In any case, the energy savings of panel heaters ranges in the area of 25- 50% over Calrod heaters with no reduction in the line speed. At the same time the product quality is improved due to more uniform and zoned heating. The reject rate is also dramatically reduced.

When you compare the initial costing, zoning, heat up time, installation, radiant efficiency, and all other considerations electric panel heaters still seem to be the better value for most applications. The panel cycle heater offers flexibility in size, maximum efficiency, consistent uniformity, and reasonable initial pricing. Your choice, of course, will depend on your particular application. If small zoning is the driving factor, then ceramic heaters are your most likely candidate.

If long off cycles in between forms is die case, then quartz tubes require a hard look. If electric rates are through the roof; and gas pricing is extremely low then catalytic heaters have to be considered. Following is a list of benefits for the available heaters. The heaters are rated from one to five, one being least favorable and five being most favorable.

## HEATER SELECTION

Selecting the proper heater is probably the most difficult part of retrofitting your thermoforming machine. The best advice, of course, is to talk to as many people in the industry as possible, especially other thermoformers who have previously retrofitted their equipment. Speak with equipment manufacturers and vendors. Look at the various types of heaters being used by the manufacturers. Find out how much experience the vendors have in retrofitting thermoforming equipment. Ask for case studies pertaining to your application. After a thorough research and review, you should be well prepared to make the final and correct decision.

## HEATER SELECTION CHART

The chart is prepared based on conversations with many thermoformers and equipment manufactures.

Heater ratings: 1 is least favorable, 5 is most favorable.

ITEM	PANEL	CERAMIC	QUARTZ TUBE	GAS CATALYTIC
Purchase Price	5	4	2	1
Efficiency	4	3	4	4
Heating cycle time of material	5	4	4	3
Response time	2	2	5	2
Initial warm up time	3 (7 min.)	4 (5 min.)	5 (10-20 sec.)	1 (20-30 min.)
Uniformity on the product	4	4	3	5
Zoning capability	4	5	3	2
Long-term cost effectiveness*	5	3	3	4
Installation	5	3	4	3
Durability	3	3	1	4
Maintenance	5	3	2	5
<b>TOTAL</b>	<b>45</b>	<b>38</b>	<b>36</b>	<b>34</b>

\* Long-term cost effectiveness is based on initial cost of heaters and installation, decreased power usage, Increased productivity, long-term maintenance costs, and insurance costs.

## CONTROLS

Just as there are many heater options, there are many control options for your thermoforming equipment. The selection of both the control and the power switching devices is dependent on the sensitivity of the produce temperature. The proper determination of which devices can best be determined by reviewing the existing control scheme and deciding the advantages and disadvantages of the operation. We suggest you speak to several local control companies to get some input and ideas. Renew your application with friends in the industry who may have retrofitted thermoforming controls recently. And finally, spend time with equipment manufacturers and equipment retrofit organizations to get the benefit of their expertise and experience.

If you have the good fortune of having in-house expertise, then you are better off putting together the control package yourself. This, of course, will reduce your cost of purchasing controls.

If you feel uncomfortable with the controls portion of the project, you will be better served by contacting a local controls specialist, thermoforming machine retrofitter or equipment supplier. The controls specialist is most likely local, and more accessible, which can be an advantage in the client of a problem with the system. However, the local controls specialist may understand controls, but may not understand your specific application well. For this reason, you may want to bring in a machine retrofitter to supply a controls package for your application.

Though they may not be local they have more experience in operating and controlling many different types of thermoforming machines. This approach may help in assuring that problems will not surface in the first place. Original equipment manufacturers (OEM's) can also be of great Control Panel assistance. Knowing how the machine was originally designed, and its limits, they can provide some in-depth perspective in ensuring a proper controls retrofit. OEM's are usually on the culling edge of technology for new applications and may be able to make use of that technology to upgrade your system. And,

once again, the best approach is to know your own capabilities and check around. As in any new venture, "it never hurts to ask!"

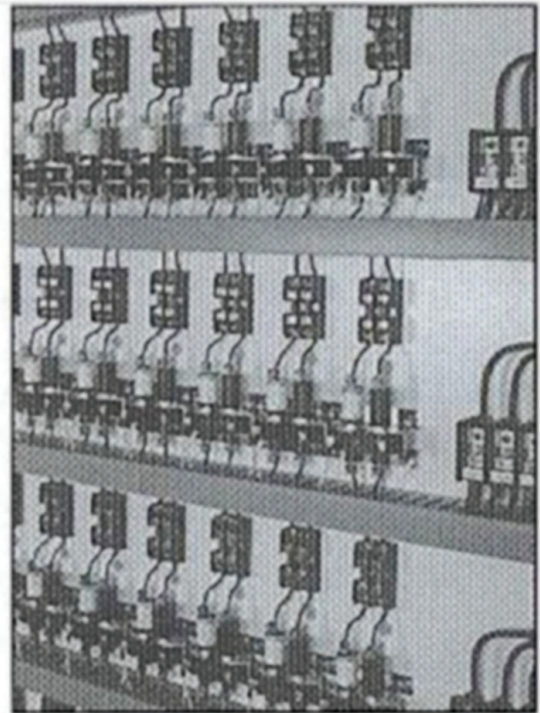

*Control Panel*

## CONTROLS OVERVIEW

Following is a brief overview of the controls available to you on the market today. It by no means covers every option available. However, it does cover the majority of applications that we see in the field. There are several areas to discuss.

They include:

- **Modes of Control**
- **Method of Control**
- **Means of Temperature Control**
- **Method of Switching Power**

**Modes of Control** are broken down into two primary categories for thermoforming applications: open loop and closed loop. The open loop system typically makes use of a percentage timer that turns the heater on for some period of time off for some other period of time. There is no form of feedback, with the exception of the operator visually determining whether there is too much heat in one area

versus another. In sheet-fed application, the open loop system is very common. The closed loop system depends on some means of sensing the temperature of the product or the heater and controlling it by means of a device that

truces that temperature input and generates an output to the heaters. This type of system is more commonly found with roll-fed thermoforming machines.

### OPEN LOOP

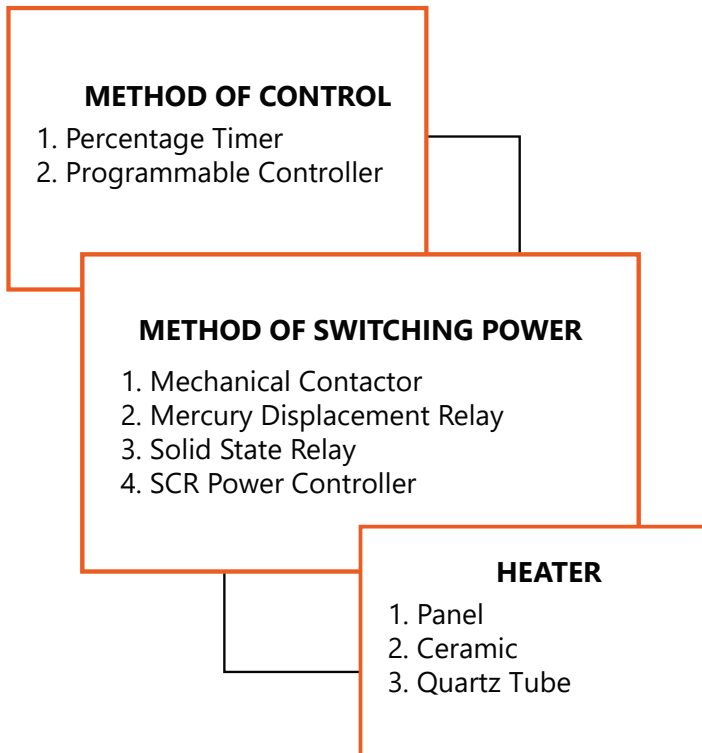

**Method of Control** offers several options, percentage timers, temperature controllers, or programmable controllers. As mentioned above, the percentage timer is used in an open loop system.

This Device is commonly used for small slicer-fed machines with few zones. While the percentage time, is the least accurate means of temperature control (typically  $\pm 10$  degrees F. maximum temperature variance), for many applications it is a sufficient means of control. The percentage timer approach, in many cases, is the most cost-efficient means of control.

The temperature controllers can be broken down into several classes. All temperature controllers take an input signal from a temperature sensing device; it is the output that varies. The output can be a dry contact, solid state relay (SSR), or analog signal.

The dry contact output is in the form of a relay or triac. The triac is all electronic device, which will have a longer life than a mechanical relay. The dry contact is used with a mechanical contractor or a mercury relay. The typical temperature variance with this control is + 7 degrees F, due to long cycle times.

The SSR output is either an AC or DC pulsed voltage that is commonly used with a higher power rated solid state relay. The approximate temperature variance with this control is  $\pm 3$  degrees F. The last form of output is the analog type that usually comes in the form of a 4 - 20 mA signal. This signal can sometimes be used with a SSR that has a signal conversion device. It is more commonly used with a Silicon Controlled Rectifier (SCR) power switching device. The following of control will have the most precise temperature control. Typical variance is  $\pm 1$  degree F. The following chart matches the temperature controller output with the proper power switching device.

### CLOSED LOOP

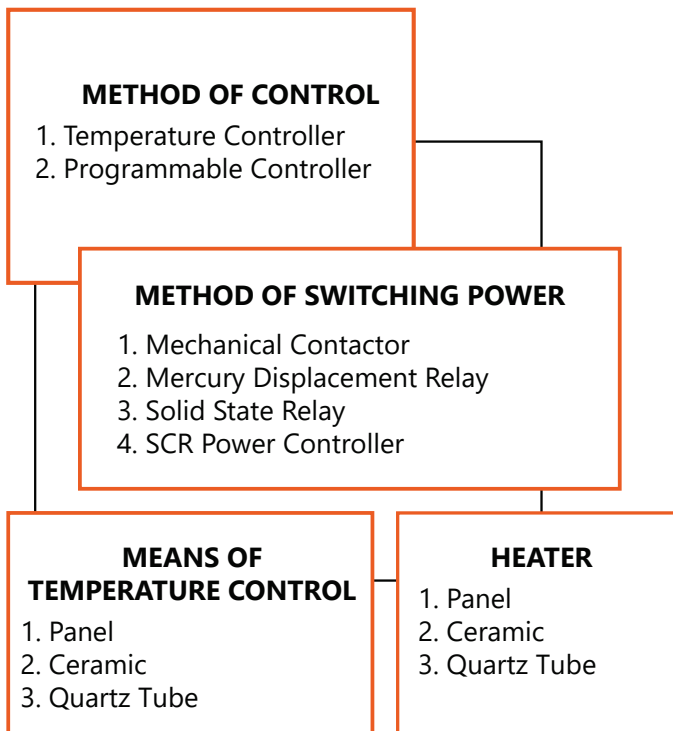

---

### Temperature Controller Output

1. Dry contact output (either mechanical contact or electronic contact - triac)
2. Solid State Relay output (pulsed NC or D/C voltage)
3. Analog output (4-20 mA or 0-5 volts)

### Power Switching Device Options

1. Mechanical Contactor
2. Mercury Displacement Relay
1. Solid State Relay (SSR)
1. SCR Power Controller
2. SSR (will an analog conversion device)

of the zones can be changed at once. An option is to store different programs in the controller for different materials or products. This can save time when setting up the system.

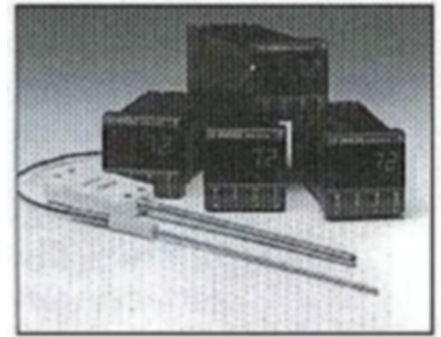

*Temperature Controller*

It also assures that the same settings are used each time. The last advantage to a controller is that by programming the heater cycling, you can assure minimum power usage. Heaters can be cycled so that when some heaters are on, other heaters are off. This reduces the peak amperage and, therefore, reduces the electrical feeder and main breaker size.

The PLC can additionally be used for the actual machine operation. Some machines have older control systems, for which parts can be hard to find. A new PLC will correct this problem, while bringing better automation to the machinery. An example of this automation is the use of macros that record the machine movements and can then play them back. This can simplify the set up for a production run.

The downside to controllers is the programming. Some thermoformers feel that they lose control due to this programming issue. Either someone in-house, a local controls person, or a machine retrofitter will have to write the ladder logic program. In turn, this program will cycle the heaters as desired for the product. When all the advantages are taken into consideration, this point of programming becomes a moot point.

**Means of Temperature Control** is performed by some type of a temperature sensing device, such as a thermocouple or a non-contact device, such as a pyrometer. There are several variations of both found in the market. The thermocouple is typically used to sense the temperature of the heater, and the pyrometer is used to sense the actual temperature of the product.

---

The programmable controller can be used as a percentage timer or a temperature controller.

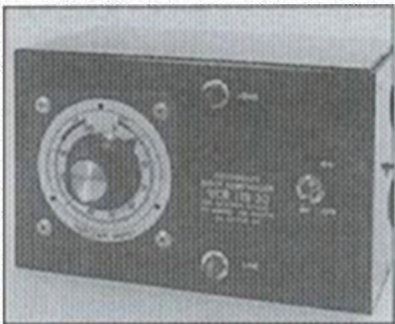

*Percentage Timer*

The device is supplied with both inputs and outputs. The quantity of inputs is usually slightly greater than the amount of outputs. On a system where the controller is used in place of percentage timers, only the outputs are used. The inputs would be used to receive the signal from a thermocouple. If there are a lot of zones on your system, then it makes sense to use a

The advantage of a programmable controller is that many zones can be controlled from one device, and the cost to control each zone is greatly reduced.

programmable controller. Another advantage of using a controller is in changing set points. All or many



*Programmable Controller*

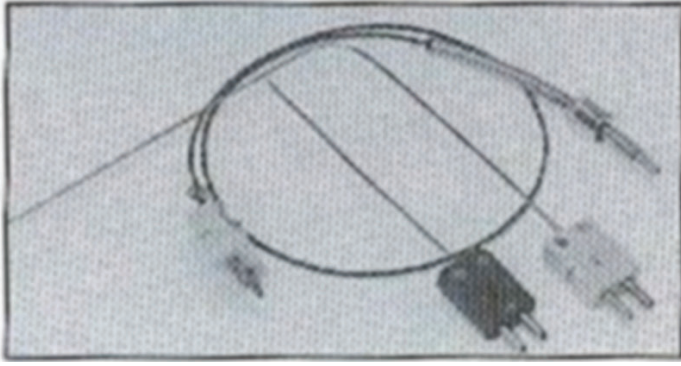

*Silicon Controlled Rectifier*

A thermocouple has been used to sense the temperature near the product, but this is not a recommended approach towards achieving good control. The thermocouple mounted in this fashion does not provide an accurate reading of either the product temperature or the heater temperature. The thermocouple is usually a K-type for applications up to 1800 °. For a J-type for applications up to 900° F. It is available in many different lengths, diameters, connection types, and sheath types. The most common thermocouple is a type-K, 1/8" diameter, 5-6" long, male plug connector, with an inconel sheath.

Though the pyrometer is not as common as the thermocouple, its use is increasing. One example is in the heating of acrylics, which requires a more exact temperature to ensure proper fanning.



*Pyrometer*

Pyrometers can be mounted outside of the oven and directed through an opening at the product or can be mounted in the oven. When mounted in an oven, the heaters, often times, have a hole cut out for the pyrometer to sense through. The pyrometer measures temperature by sensing the heat being radiated from an object (such as the acrylic sheet) that sensing of heat is ultimately converted into a millivolt signal that can be used by the temperature controller. It is important to know the emissivity of the product in order to get an accurate temperature reading. Emissivity is a measurement of the absorption and reflective properties of the material. When used in an oven, the pyrometer should be cooled by either air or water. The means of cooling depends on the temperature around the sensing device.

**Method of Switching Power** can be performed in the following means: mechanical contactor mercury displacement relay, solid state relay, or SCR power controller. You may ask yourself the question why do I need a power switching device separate from the percentage timer, temperature controller, Of programmable controller? The answer is simple. Most controllers or timers have an output that have a low power rating.

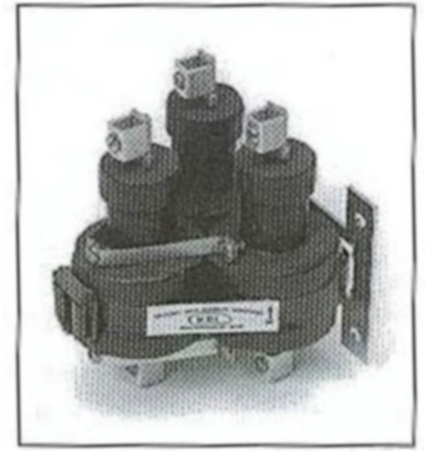

*Mercury Relay*

So low, that it typically can not be used to power a heater. That is why the power switching device is put in between the controller and the heater. There are some controllers and timers that have higher power ratings. In that case, a separate power switching device is not required. Often times, the term relay or contactor is used interchangeably, A relay usually refers to a low power device and a contactor refers to a higher power mechanical device. The mechanical contactor is the least expensive means of switching power. Because of the constant on/off cycle used in the thermoforming industry, the

mechanical contactor is not the best choice. The mercury displacement relay is a better way of switching power in a thermoforming operation.

It is an extremely reliable and cost-effective means of switching power, but it can be too slow for some applications. It is more commonly used in sheet-fed operations. While the mercury displacement relay can be used in continuous machines, the SSR or SCR type are more common.

The solid state relay (SSR) is the most commonly used power switching device being utilized today in the thermoforming marketplace, and the



*Solid State Relay*

Pricing on these devices is quite reasonable. The control is just right for most applications. They are very reliable. In many cases, SSR's require only a heat sink for cooling, as opposed to fan cooling. It should be noted that if a large quantity of SSR's are used in a single enclosure, then fan cooling, as a minimum, is required. Solid state relays have power ratings up to 90 amps. If the power rating exceeds 90 amps, then the SCR power controller would have to be used in place of the SSR. Because there are many zones in a thermoforming application, the current draw per zone does not normally exceed 90 amps. The SSR is triggered by a pulled signal from the controller. The SSR is available as a single or three phase devices, or several SSR's can be used together in a three-phase application.

The use of an analog card with an SSR is becoming much more common. This device is typically half the cost of a SCR device with the same fast switching time.

The most expensive, though the best form of control, is the SCR type of power switching

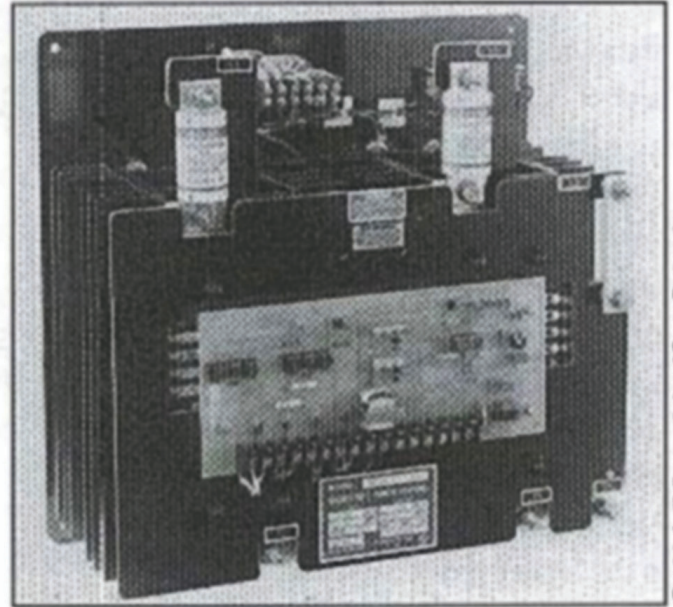

*Silicon Controlled Rectifier*

device. This is the only means of switching that is truly variable. The SSR may seem to be variable but is actually switching on and off once every second. (With an analog card in conjunction with the SSR, the switching time is much faster.) The SCR is switching on/off many times a second. Therefore, the switching becomes transparent. The SCR is available in two varieties: phase angle and zero crossing control.

Phase angle control is more accurate than the zero crossing type: It is also more expensive and can generate electrical noise problems. The zero crossing type is more commonly used in the thermoforming application. It provides all the control required for this application. The one area where phase angle SCR switching devices are commonly used is with T3 lamps because of the high inrush current. T3 lamps are short wave infrared heaters, which are not typically used in thermoforming applications.

## OTHER CONSIDERATIONS

When retrofitting a thermoforming machine, the two most important items are the heaters and the controls. However, there are many other little details that need to be worked out. Following is a checklist of other items that should be considered when retrofitting your equipment:

Will the compressor/vacuum pump or rank size suffice for the projected increase in line speed?

- Is the drive train properly sized for the new line speed?
- Is the oven area large enough for the new heaters?
- Is the oven enclosed for maximum use of the available heat?
- Check existing cylinders, motors, drive chain, platen, servo's, limit switches, sensing devices, hoses, etc., for wear and possible change out while the machine is being retrofitted.
- Check mold cooling to see if more water/low is required with die higher production rate.
- Check the chain mils for proper cooling.
- Will the trim press keep up with the increased line speed?
- Will the electrical service to the machine provide enough power for the new heater load?

This is the short list of items that need to be addressed. If you have other checklist items, please let us know.

## CONCLUSION

With the information enclosed in this guidebook, along with some good common sense, you are on your way towards retrofitting your thermoforming equipment. From an economic standpoint, in many cases, this approach is your best decision. The increase in productivity and machine capacity typically pays back the retrofit cost in less than a year.

It will be an exciting project with all the ups and downs that are common with a project such as this. But, the good news is by following this guide and doing your homework up front, there will be a lot more ups and very few downs. So, good luck and take plenty of pictures to share your experiences with us. It will help you and the next person in line who is willing to accept the challenge and reap the many benefits to be gained by letting their thermoforming system. Retrofitting can help to avoid overtime, second shift, or a new equipment purchase. But most importantly, retrofitting will help improve your bottom line.

The following companies have provided pictures used in this guidebook. All of these companies can provide heaters and/or controls for your retrofit needs.

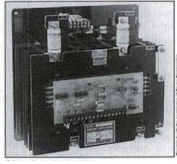

1 Payne Engineering  
Scott Depot, WV  
Phone: 304-757-7353

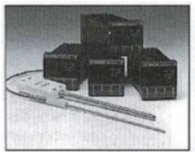

2 Omega Engineering, Inc.  
Stamford, CT 06907  
Phone: 1-800-826-6312

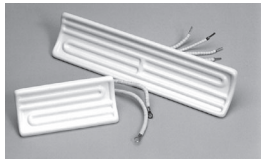

3 Tempco Electric Heater Corporation  
Woodale, IL  
Phone: 708-350-2252



4 Allen-Bradley  
Milwaukee, WI  
Phone: 414-382-4444

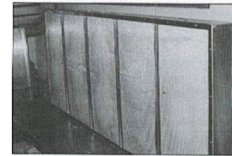

5 Infrared Technologies  
Kansas City, MO  
Phone: 816-241-4433

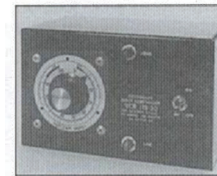

6 Chromalox™  
Wiegand Industrial Division  
Pittsburgh, PA  
Phone: 412-96-3800





# **SOLAR PRODUCTS INC.**

## **THE INFRARED HEATER COMPANY**

### **ABOUT SOLAR PRODUCTS**

In 1956, Richard Eck, the founder, had a few good ideas about making a better infrared heater. Today, over 60 years later, that philosophy continues to radiate throughout Solar Products. Many ideas and several patents later, Solar Products has become the largest supplier of medium wave infrared heaters in the U.S. market. At Solar Products, we don't build systems, we manufacture infrared heaters. Maybe that's why we've grown to be the largest supplier of infrared heaters in the industry... by staying focused.

**[www.solarproducts.com](http://www.solarproducts.com)**