

Fluid Cooling Industrial & Mobile OCA Series

Performance Notes

- Young Radiator – OCS interchange (approximate)
- American Industrial – AOCS interchange (approximate)
- High efficiency, light weight, low fouling extruded core design
- Rugged construction with a patented T-BAR brazed aluminum core captured in steel framing
- Both mobile and industrial applications
- High flow capacity; with a flow range from 20-500 GPM
- Ability to handle high viscosity fluids like gear oil cooling
- Standard sizes available with short lead time
- Hydraulic circuits
- Enclosed fan cooled standard – TEFC



Option
External pressure bypass

Ratings

Maximum Operating Pressure
250 PSI (17 BAR)

Maximum Operating Temperature
350°F (177°C)

Materials

Fan Blade Composite with cast aluminum hub

Cabinet Steel with baked enamel finish

Connections Aluminum

Motor Support Steel

Shroud Steel

Core Brazed aluminum

Motor TEFC & Hydraulic motor



Dimension Range

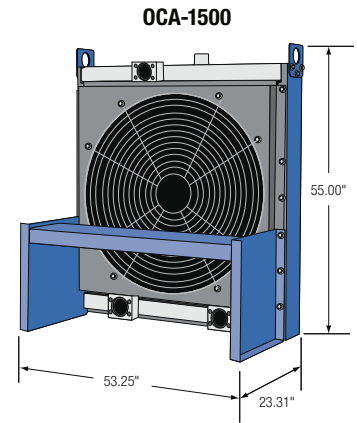
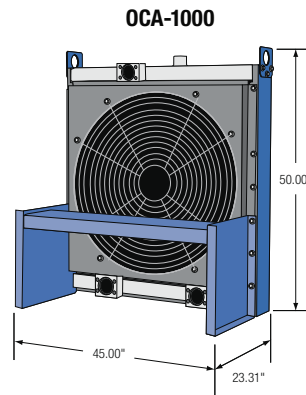
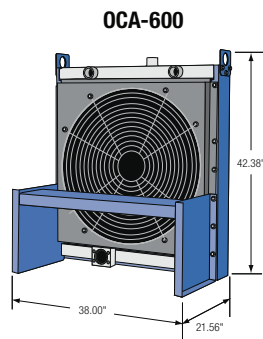
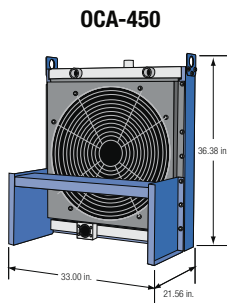

How to Order

OCA	-		-		-		-		-	
Model Series OCA - Standard		Model Size Selected		Connection Type 2 - SAE		External Bypass BLANK - No Bypass 30 - 30 PSI 60 - 60 PSI		Specify Motor Required 0 - No Motor 3 - Three Phase 6 - 575 Volt 9 - Hydraulic Motor 11 - Three PH Explosion Proof 18 - Three PH IEC		Material Options HC - Heresite Coating (Core) G - Galvanized Steel (Cabinet) SFG - Stainless Steel (Fan Guard)

This is a partial flow pressure bypass only. It is not designed to be a full flow system bypass.

Dimensions

OCA-450 & 600

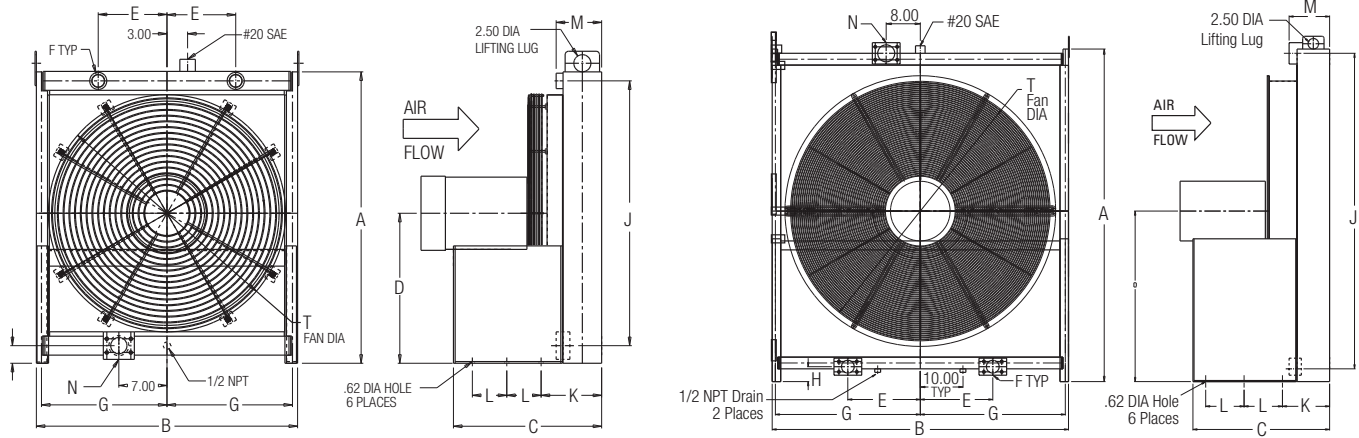

Model	A	B	C	D	E	F	G	H	J	K	L	M	N	T	Shipping Weight (LBS)	DBA at 3 FT
OCA-450	36.38	33.00	21.56	18.50	8.00	#24	15.75	4.12	28.75	8.81	5.00	6.62	2.00	24.00	400	81
OCA-600	42.38	38.00	21.56	21.81	10.00	#24	18.25	2.56	35.50	8.81	5.00	6.62	2.50	32.00	497	84
OCA-1000	50.00	45.00	24.56	26.25	10.50	2.00	21.75	4.19	45.50	7.81	7.50	7.50	3.00	36.00	690	88
OCA-1500	55.00	53.25	23.31	28.50	12.50	2.00	25.75	4.31	49.75	7.79	7.00	8.50	3.00	42.00	832	92
OCA-2000	65.00	60.00	29.06	33.00	15.00	3.00	29.00	4.00	58.00	11.06	7.50	8.56	3.00	48.00	1223	96
OCA-2500	72.00	67.25	34.25	37.00	17.00	3.00	32.88	3.25	67.50	11.06	7.50	9.50	4.00	54.00	1723	96
OCA-3100	78.00	69.50	32.06	40.00	17.00	3.00	34.00	3.00	74.00	11.06	9.00	9.50	4.00	60.00	1806	96

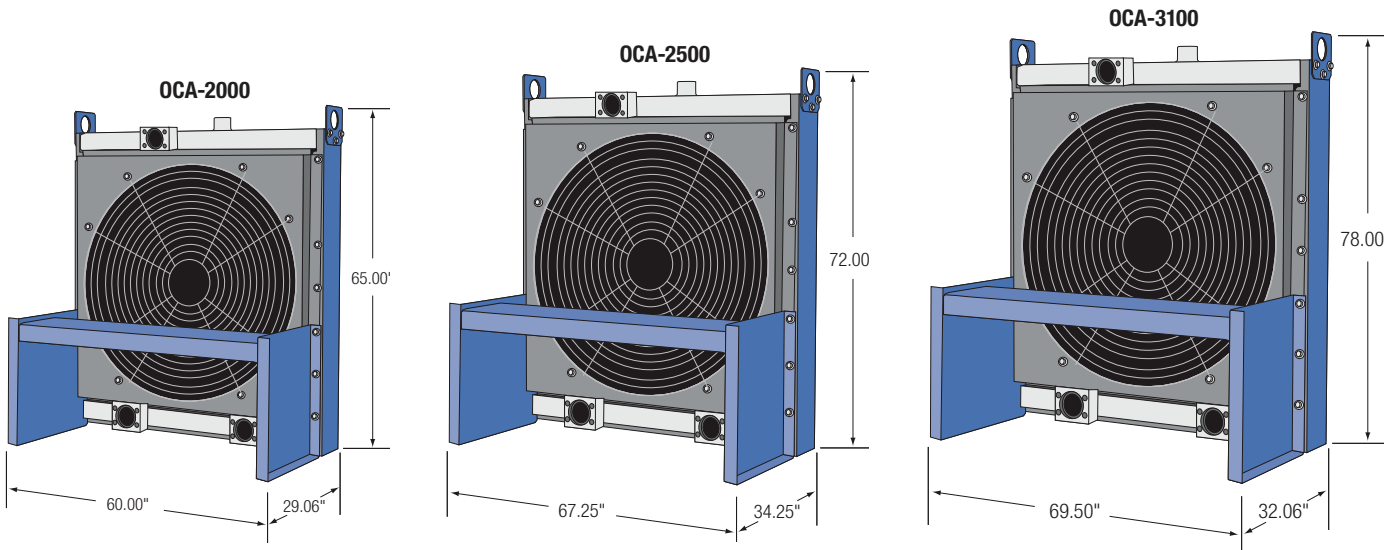

Connection Conversion Kits - order as separate line item

	Part Number						
	OCA-450	OCA-600	OCA-1000	OCA-1500	OCA-2000	OCA-2500	OCA3100
2 Pass SAE (Flange Cover)	12076	12011	12012	12012	12012	12013	12013
1 Pass NPT	51166	51168	51170	51172	51174	51175	51178
2 Pass NPT ³	51167	51169	51171	51173	51175	51177	51179
1 Pass BSPP	Consult Factory						
2 Pass BSPP ³	Consult Factory						
Fill Plug (#20 SAE) ⁴	50732						

¹ Available for 2 Pass unit only. Pressure tolerance is (+5 PSI/-0 PSI). Consult factory for details.

² Use HC-G-SFG if all three add-ons are desired.

³ Two Pass adapter kits already include cover plate.

⁴ Ports do not come plugged unless specified at time of order.

External Pressure Bypass Option (Extra port is removed for bypass options)

OCA 450 & 600

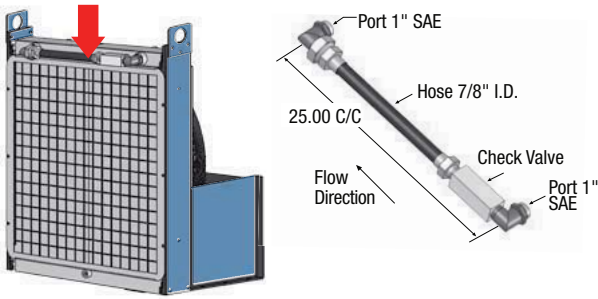

OCA 1000 - 3100

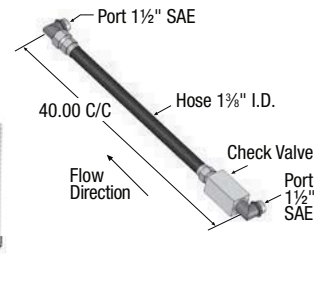

Performance Curves

One Pass

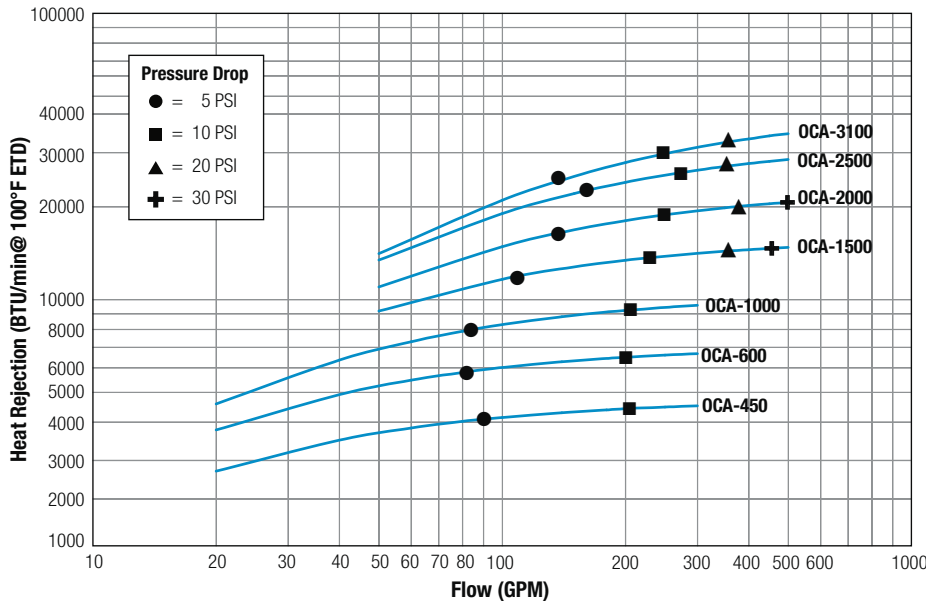

Two Pass

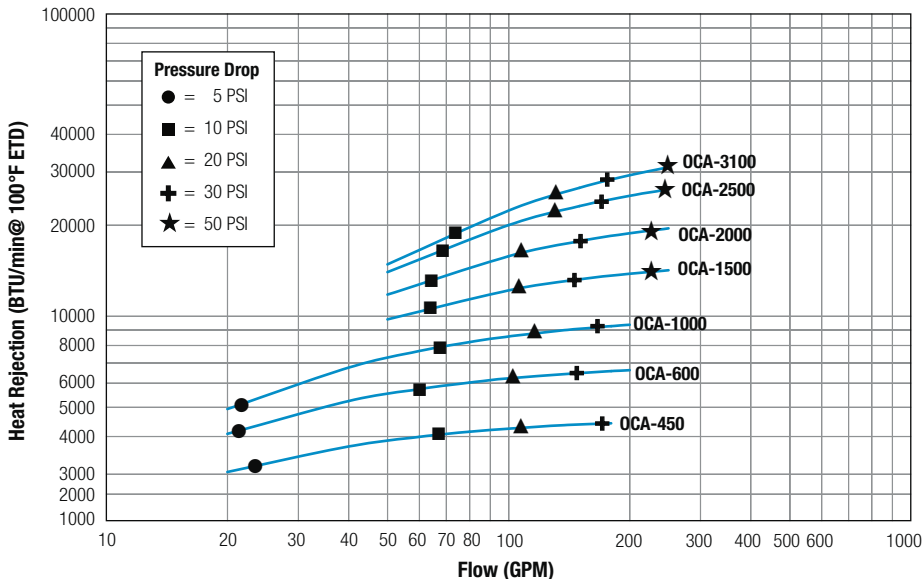

Piping Diagram

OCA 450 & 600 One Pass

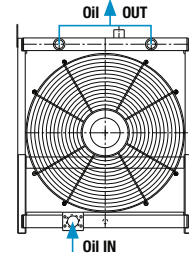

OCA 450 & 600 Two Pass

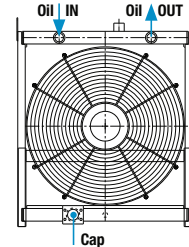

1000 - 3100 One Pass

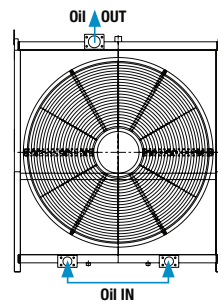

1000 - 3100 Two Pass

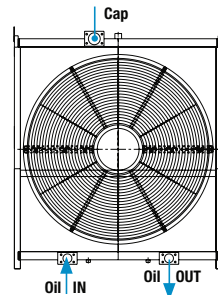

Selection Procedure

Performance Curves are based on 50 SSV oil entering the cooler 100°F higher than the ambient air temperature used for cooling. This is also referred to as a 100°F Entering Temperature Difference (ETD).

STEP 1 Determine the Heat Load. This will vary with different systems, but typically coolers are sized to remove 25 to 50% of the input nameplate horsepower.
(Example: 100 HP Power Unit x .33 = 33 HP Heat load.)
Convert HP to BTU/MIN: HP x 42.4 = BTU/MIN

STEP 2 Determine Entering Temperature Difference (ETD).
Desired oil entering cooler °F – Ambient air temp. °F = Actual ETD

STEP 3 Determine Curve Horsepower Heat Load.
Enter the information from above:
ETD Temperature Correction Factor:
$$\text{BTU/MIN}_{\text{corrected}} = \text{Input BTU/MIN} \times \frac{100 \times C_v}{\text{Desired ETD}}$$

Enter curves at oil flow through cooler and curve horsepower.
Any curve above the intersecting point will work.

STEP 4 Determine Oil Pressure Drop from Curves:
● = 5 PSI ■ = 10 PSI ▲ = 20 PSI + = 30 PSI ★ = 50 PSI
Multiply pressure drop from curve by correction factor found in oil ΔP correction curve.

- Determine heat load.
Generally, about 25% to 33% of the system horsepower is removed.
 $300 \text{ HP} \times 0.33 = 99 \text{ HP}$

- Since the graphs have the heat load in terms of BTU/MIN, the units must be converted.
 $99 \text{ HP} \times 42.4 = 4,199 \text{ BTU/MIN}$

- Calculate the entering temperature difference (ETD). The ETD is the inlet oil temperature minus the entering air temperature.
 $\text{ETD} = 200 - 75 = 125$

- Calculate the corrected curve heat load.
Corrected curve heat load = actual heat load x (100/ETD) x Cv (viscosity correction factor obtained from the Cv table).
 $4,199 \text{ BTU/min} \times (100/125) \times 1.02 = 3,426 \text{ BTU/MIN}$

- Find the intersection point between the corrected heat load and flow rate on the performance curves. Any curve above this point will work for this application. Usually the smallest cooler is most desired. In this case the intersecting point on the single pass graph indicates that the OCA-450 will suffice.

- The pressure drop should be found next. Find the point on the curve that is directly above the intersecting point. This point on the curve indicates the pressure drop.

$$\Delta P \approx 6 \text{ PSI}$$

- These curves are made for SAE 10 oil entering at 200°F. Therefore, the pressure drop needs to be corrected. The 1.24 is the pressure drop correction factor obtained in the Cp table.

- $P_{\text{CORRECTED}} = 6 \times 1.24 = 7.44 \text{ PSI}$

Example

Fluid = SEA 20 oil
System Electric Nameplate Horsepower = 300 HP
Entering Temperature = 200°F
Ambient Temperature = 75°F
Flow Rate = 200 GPM

C_v Viscosity Correction Factors

Entering Liquid Temp	SAE 5	SAE 10	SAE 20	SAE 30	SAE 40	ISO 22	ISO 32	ISO 46	ISO 68	ISO 100	ISO 150	ISO 220	ISO 320	MIL-L 7808	Ester Polyglycol	Phosphate	50% EG
100	1.12	1.16	1.26	1.39	1.46	1.09	1.15	1.19	1.27	1.38	1.44	1.57	1.85	1.20	0.93	0.84	0.86
110	1.10	1.13	1.21	1.33	1.41	1.07	1.14	1.17	1.26	1.32	1.40	1.49	1.68	1.15	0.90	0.81	0.85
120	1.07	1.11	1.18	1.28	1.36	1.05	1.12	1.15	1.21	1.28	1.36	1.41	1.54	1.10	0.89	0.80	0.85
130	1.05	1.09	1.14	1.25	1.30	1.04	1.10	1.14	1.18	1.25	1.31	1.35	1.45	1.06	0.86	0.78	0.84
140	1.04	1.06	1.12	1.20	1.26	1.03	1.09	1.11	1.17	1.21	1.27	1.31	1.40	1.04	0.85	0.77	0.83
150	1.02	1.05	1.10	1.17	1.23	1.03	1.07	1.10	1.14	1.18	1.23	1.28	1.34	1.02	0.84	0.75	0.83
200	0.99	1.00	1.02	1.05	1.08	0.99	1.00	1.01	1.02	1.03	1.09	1.10	1.15	0.99	0.80	0.72	0.81
250	0.96	0.97	0.98	0.99	1.00	0.96	0.97	0.97	0.97	0.98	1.00	1.02	1.03	0.98	0.77	0.70	0.80

C_p Pressure Drop Correction Factors

Entering Liquid Temp	SAE 5	SAE 10	SAE 20	SAE 30	SAE 40	ISO 22	ISO 32	ISO 46	ISO 68	ISO 100	ISO 150	ISO 220	ISO 320	MIL-L 7808	Ester Polyglycol	Phosphate	50% EG
100	2.04	2.44	4.44	6.44	8.84	1.11	1.57	1.86	2.58	4.23	6.48	9.42	13.60	1.30	3.04	3.54	0.770
110	1.74	2.14	3.64	5.14	6.74	1.08	1.49	1.76	2.39	3.77	5.74	8.37	11.67	1.24	2.44	2.94	0.760
120	1.54	1.84	3.04	4.24	5.64	1.06	1.42	1.64	2.19	3.30	5.95	7.27	9.77	1.18	2.14	2.54	0.749
130	1.44	1.64	2.64	3.44	4.54	1.03	1.34	1.53	1.98	2.84	4.18	6.23	7.84	1.12	1.94	2.24	0.738
140	1.34	1.54	2.27	2.94	3.74	1.01	1.27	1.42	1.79	2.42	3.51	5.24	6.15	1.07	1.94	2.04	0.726
150	1.24	1.34	1.94	2.54	3.14	0.99	1.21	1.34	1.65	2.08	2.94	4.39	4.81	1.02	1.74	1.94	0.716
200	0.97	1.00	1.24	1.44	1.64	0.93	1.03	1.12	1.22	1.37	2.63	1.78	1.99	0.94	1.24	1.34	0.675
250	0.85	0.86	0.96	1.01	1.09	0.89	0.97	1.00	1.07	1.15	1.25	1.26	1.27	0.87	1.04	1.09	0.596

Specifications

Electric Motor Data

(3 Phase TEFC)

Model	Motor HP	Phase	HZ	Voltage	RPM	Nema Frame	Full Load Amps	Net Weight
OCA-450	3	3	60	208-230/460	1725	182T	9.5-8.6/4.3	68
OCA-600	3	3	60	230/460	1160	213T	10/5	125
OCA-1000	5	3	60	230/460	1160	215T	16/8	138
OCA-1500	5	3	60	230/460	1160	215T	16/8	138
OCA-2000	10	3	60	230/460	1175	256T	28.8/14.4	269
OCA-2500	15	3	60	230/460	1175	284T	39.4/19.7	361
OCA-3100	20	3	60	230/460	1175	286T	52/26	368

(3 Phase Explosion Proof Class I Group D & Class II Group F&G)

Model	Motor HP	Phase	HZ	Voltage	RPM	Nema Frame	Full Load Amps	Net Weight
OCA-450	3	3	60	230/460	1750	182T	9.6/4.8	134
OCA-600	3	3	60	230/460	1160	213T	9.6/4.8	147
OCA-1000	5	3	60	230/460	1160	215T	16.2/8.1	161
OCA-1500	5	3	60	230/460	1160	215T	16.2/8.1	161
OCA-2000	10	3	60	230/460	1175	256T	28.8/14.4	357
OCA-2500	15	3	60	230/460	1170	284T	39/19.5	436
OCA-3100	20	3	60	230/460	1175	286T	51/25.5	522

(3 Phase 575V TEFC)

Model	Motor HP	Phase	HZ	Voltage	RPM	Nema Frame	Full Load Amps	Net Weight
OCA-450	3	3	60	575	1750	182T	3.4	68
OCA-600	3	3	60	575	1160	213T	4.1	111
OCA-1000	5	3	60	575	1160	215T	6.0	122
OCA-1500	5	3	60	575	1160	215T	6.0	122
OCA-2000	10	3	60	575	1180	256T	11.5	286
OCA-2500	15	3	60	575	1180	284T	15.0	425
OCA-3100	20	3	60	575	1175	286T	20.0	452

(3 Phase Metric/IEC)

Model	Motor HP	Phase	HZ	Voltage	RPM	Nema Frame	Full Load Amps	Net Weight
OCA-450	2.2/3	3	60	208-230/460	1750	100	8.5-8.2/4.1	68
OCA-600	2.2/3	3	60	230/460	1160	132	9.6/4	110
OCA-1000	3.7/5	3	60	230/460	1160	132	17.6/8.8	123
OCA-1500	3.7/5	3	60	230/460	1160	132	17.6/8.8	123
OCA-2000	7.5/10	3	60	230/460	1180	160	28.4/14.2	247
OCA-2500	11/15	3	60	230/460	1180	180	42/21	361
OCA-3100	15/20	3	60	230/460	1175	180	52/26	368

Hydraulic Motor Data

Hydraulic Motors

Model	HP	Pressure (PSI)	Flow (GPM)	RPM	Displacement (CUIN/REV)
OCA-450	3	870	11.1	1750	1.37
OCA-600	3	1305	8.0	1160	1.37
OCA-1000	5	2030	8.0	1160	1.37
OCA-1500	5	2030	8.0	1160	1.37
OCA-2000	10	2090	8.2	1175	1.37
OCA-2500	15	2900	8.2	1175	1.71
OCA-3100	20	2320	13.3	1175	2.2

The OCA Advantage

T-BAR™ is a flexible design, high performing, and a cost-effective aluminum solution.

Tubular Micro Channel Extrusion (T-BAR)

T-BAR is manufactured with Alloy 1100 aluminum micro channel and bars, **with Zinc flame-sprayed extruded tubes and zinc alloy coated fins**, in our patented in-house tube-to-bar brazing process using a Nocolok CAB (Controlled Atmosphere Brazing) brazing technology furnace. Because our tubes are a solid extrusion, T-BAR is very robust — with no tube seams to fail and leak.



T-BAR CORE IN OCA ASSEMBLY

Advantages

T-BAR provides advantages and value far beyond typical aluminum core designs.

- Extruded tubes for a leak free design
- Flows high viscosity fluids
- Low pressure drop due to absence of internal turbulator
- Resistance to fouling—transfer fluids without plugging
- Great for cooling cutting fluids or gear lube
- Resistant to salt spray and salt air
- Standard Zinc infused/coated core & fins for up to 10 times protection in salt conditions
- Domestic built
- Optional core for BOL model

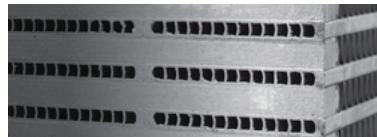

HIGH-PERFORMANCE

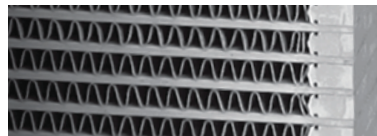

LOW-CLOGGING

T-BAR Manufacturing Process

