

The BRAWN Experience

Until you try a BRAWN Mixer, you can only imagine how good mixing can be. Our mixer designs are inspired by decades of experience in the mixer industry. We build mixers that combine quality components and superior features with internationally accepted design standards. We are an **ISO 9001** registered company. BRAWN's unique modular design concept provides for interchangeability between direct drive and gear drive for added versatility. Our drives meet all applicable AGMA and ASTM standards. Brawn's motor options are unparalleled due to the use of standard NEMA or IEC configurations. At BRAWN we are committed to providing you with guaranteed solutions to your mixing requirements. So, why trust your process to anything less?

BRAWN... Your Full Line Mixer Resource



BRAWN makes a full line of mixers to meet all your mixing needs. Call us for more information.

Special Alloys

If the wetted components in your current mixer come under chemical attack, ask your BRAWN representative about one of the many special alloys available.



**THERMAL
PRODUCTS
INC.**
Engineered Solutions To
Industrial Applications

Thermal Products, Inc. / Phone: (518) 877-0231 / Email: sales@thermalproducts.com / Website: www.thermalproducts.com

We are committed to being the Best Solution to your liquid mixing problems!

GUARANTEE:

Brawn Mixer guarantees that in the case of failure due to faulty material or workmanship we will repair or replace the defective equipment for the first year after shipment. Furthermore, Brawn will provide in writing a guarantee corresponding exactly with that of any other mixer manufacturer's guarantee when presented with written verification and a purchase order for the corresponding mixer.



BRAWN™
MIXER, INC.

BRAWN MIXER, INC.

3389 128th Avenue

Holland, Michigan 49424 USA

616-399-5600 • FAX 616-399-3084

E-mail brawn@brawnmixer.com

Visit our Web Site: www.brawnmixer.com

YOUR BRAWN MIXER REPRESENTATIVE:



BRAWN™
MIXER, INC.



MIXING SOLUTIONS

**MIXING SOLUTIONS FOR
PETROLEUM, PULP & PAPER,
CHEMICAL & FOOD
APPLICATIONS**

Side Entering Series

BRAWN side entry mixers are available in a variety of configurations for a wide range of applications including pulp and paper, petroleum, chemical and food processing to name a few.

Belt driven and gear driven designs can be equipped with stuffing boxes, or mechanical seals depending upon your needs. For ease of maintenance there is an optional shut off device that permits work on seals without emptying tank contents.

BGMSE

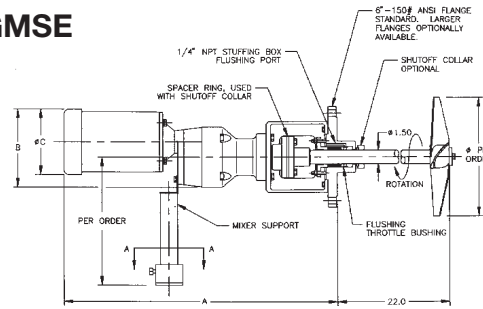

BVSE

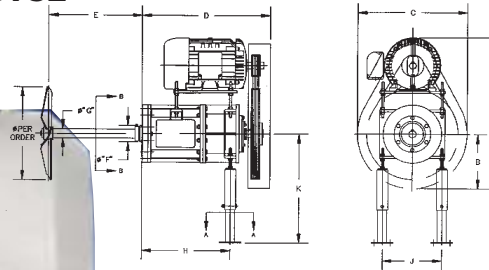

Options

Mechanical Seals

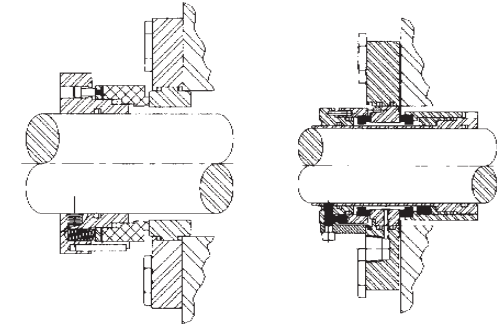

Stuffing Boxes

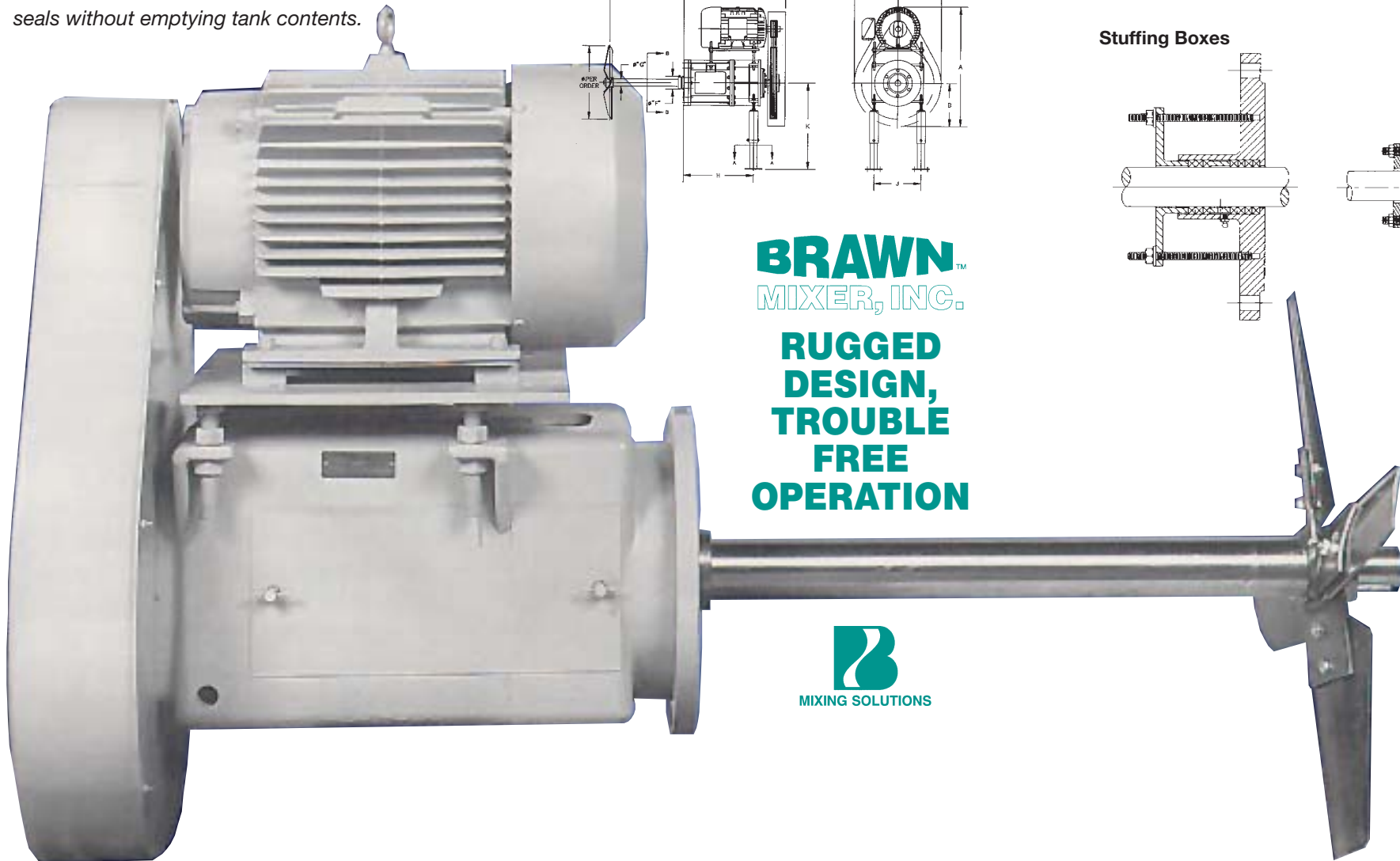
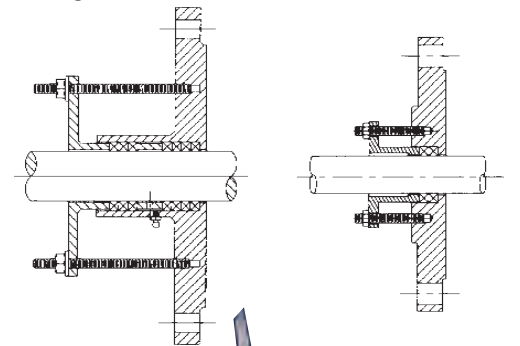

BRAWN™
MIXER, INC.

**RUGGED
DESIGN,
TROUBLE
FREE
OPERATION**

