



**THERMAL  
PRODUCTS** INC.  
Engineered Solutions To  
Industrial Applications

# **BRAWN**™ MIXER, INC.



MIXING SOLUTIONS

**MIXING  
SOLUTIONS  
TO BIG  
PROCESS  
PROBLEMS**

## BWG Series

The BWG offers versatility in horsepower range and output speeds in a compact, right-angle mixer drive. It is also available with optional drywell construction, with a wide range of mounting configurations. One of its greatest features is the high gear ratio for low-speed applications, such as flocculation or polymer blending.

BWG SERIES										
CASE SIZE	A	B	ØC	D	E	F	G	H	I	BASIC WEIGHT*
11	7.0	7.38	.44	4.0	2.0	2.88	20.0	10.0	.25	30 lbs.
12	8.2	10.13	.56	5.75	2.88	4.0	22.8	12.2	.38	75 lbs.
13	10.0	11.88	.56	6.12	3.06	4.75	24.3	13.6	.38	100 lbs.

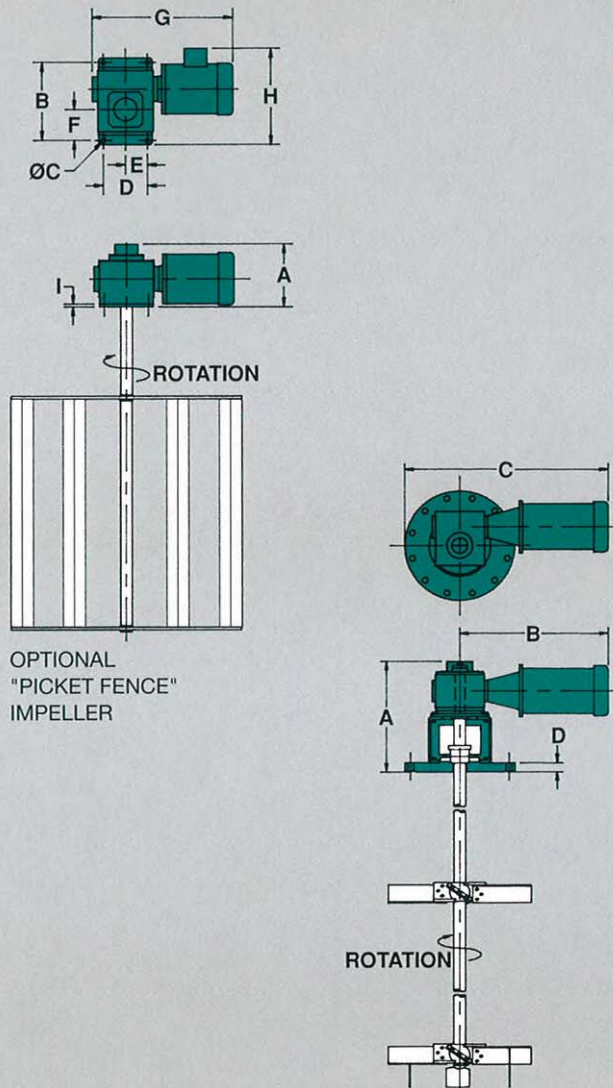

OPTIONAL  
"PICKET FENCE"  
IMPELLER

BWG SERIES / CLOSED TANK						
CASE SIZE	A	B	C	D	STD. ANSI FLANGE	BASIC WEIGHT*
11	20.5	16.7	23.5	1.5	8" 150 lbs.	120 lbs.
12	21.7	18.3	26.3	1.5	10" 150 lbs.	240 lbs.
13	23.5	19.1	27.1	1.5	10" 150 lbs.	270 lbs.

## BRM Series

These "brute-force" mixers are available to over 100 HP, with a variety of output speeds. The spiral bevel and helical gear set provide ratio change capability. It features drywell construction around the low-speed shaft for positive lubricant containment. Options include mechanical or lip seals, and stuffing boxes for closed-tank applications.

BRM SERIES								
CASE SIZE	A	B	ØC	D	E	F	G	BASIC WEIGHT*
30	19.0	22.5	.88	13.25	5.75	24.5	57.4	940 lbs.
40	18.0	22.5	.88	15.00	6.75	24.5	64.8	1130 lbs.
50	19.8	25.25	1.0	16.25	7.25	27.5	73.8	1460 lbs.
60	22.1	27.5	1.12	21.75	8.38	29.75	86.0	2150 lbs.
70	23.3	32.5	1.12	24.00	9.75	35.0	90.1	2820 lbs.
80	26.5	38	1.38	30.00	11.50	41.0	98.5	4170 lbs.
90	26.5	38	1.38	30.00	11.50	41.0	98.5	4260 lbs.

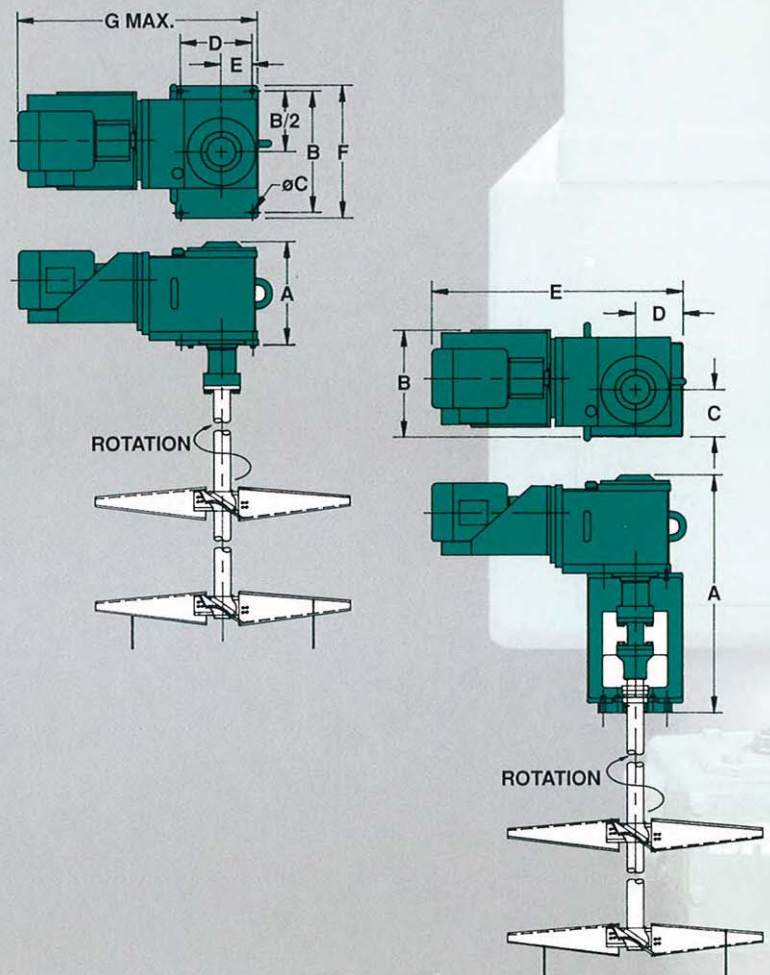

BRM SERIES / CLOSED TANK							
CASE SIZE	A	B	C	D	E	STD. ANSI FLANGE	BASIC WEIGHT*
30	44.5	19.9	8.75	8.75	59.5	8" 150 lbs.	1380 lbs.
40	45.5	24.3	9.25	9.25	66.3	10" 150 lbs.	1530 lbs.
50	50.5	27.1	10.0	10.0	75.3	12" 150 lbs.	1740 lbs.
60	57.7	27.7	11.5	11.5	76.5	12" 150 lbs.	2550 lbs.
70	60.5	31.5	12.4	12.4	84.0	14" 150 lbs.	3430 lbs.
80	68.0	35.4	14.5	14.5	98.5	14" 150 lbs.	4720 lbs.
90	68.0	35.4	14.5	14.5	98.5	14" 150 lbs.	4800 lbs.



MIXING SOLUTIONS

## BTO Series

One of the workhorses of the Brawn line, the BTO mixer is all-helical gear reduction, providing both high torque and high efficiency. It is available in open or sealed-tank versions. Motor options include NEMA and metric standards - one (1) HP through 10 HP. The BTO can be angle mounted to eliminate the need for tank baffles.

BTO SERIES							
CASE SIZE	A	B	ØC	D	E	F	BASIC WEIGHT*
2	12.0	12.0	.75	.63	16.5	23.6	135 lbs.
3	12.0	12.0	.75	.75	17.8	24.6	180 lbs.
4	16.5	10.0	.88	.88	19.1	29.5	265 lbs.

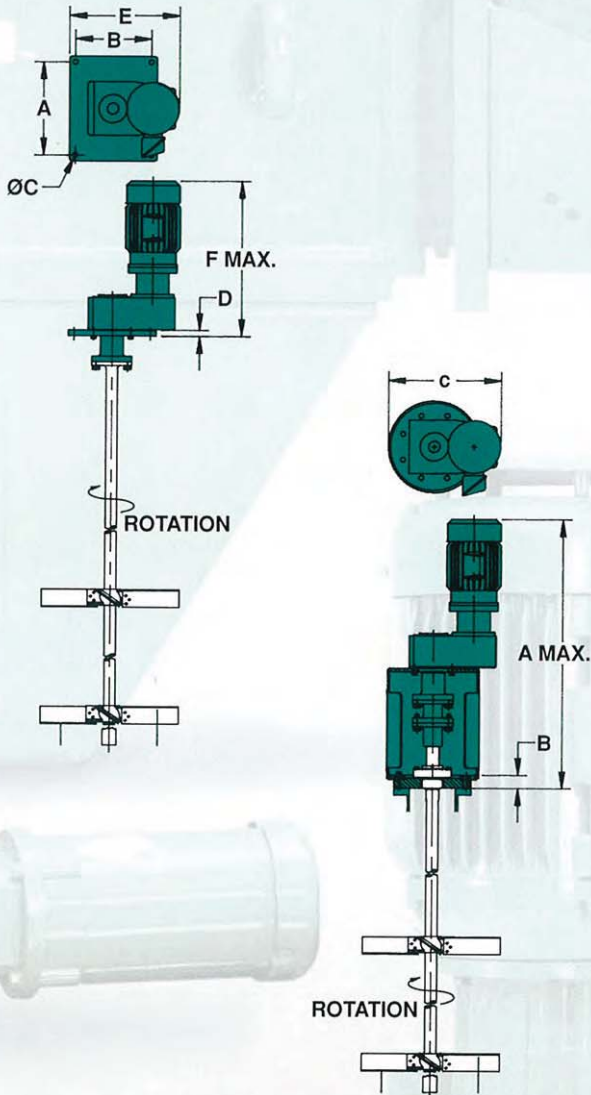

BTO SERIES / CLOSED TANK					
CASE SIZE	A	B	C	STD. ANSI FLANGE	BASIC WEIGHT*
2	43.5	2.4	16.5"	8" 150 lbs.	285 lbs.
3	45.5	2.4	17.8"	8" 150 lbs.	330 lbs.
4	51.2	2.4	19.4"	8" 150 lbs.	440 lbs.

## BTD Series

Many mixer applications require drywell construction for positive prevention of lubricant contamination to the process. The BTD Series mixer provides this feature, along with an all-helical gear box in a wide range of output speed options, and standard 3 to 25 HP.

BTD SERIES							
CASE SIZE	A	B	ØC	D	E	F	BASIC WEIGHT*
20	32.6	12.0	1.0	12.0	6.0	1.0	230 lbs.
21	37.0	14.0	1.0	14.0	7.0	1.0	400 lbs.
22	41.8	16.0	1.0	16.0	8.0	1.25	485 lbs.

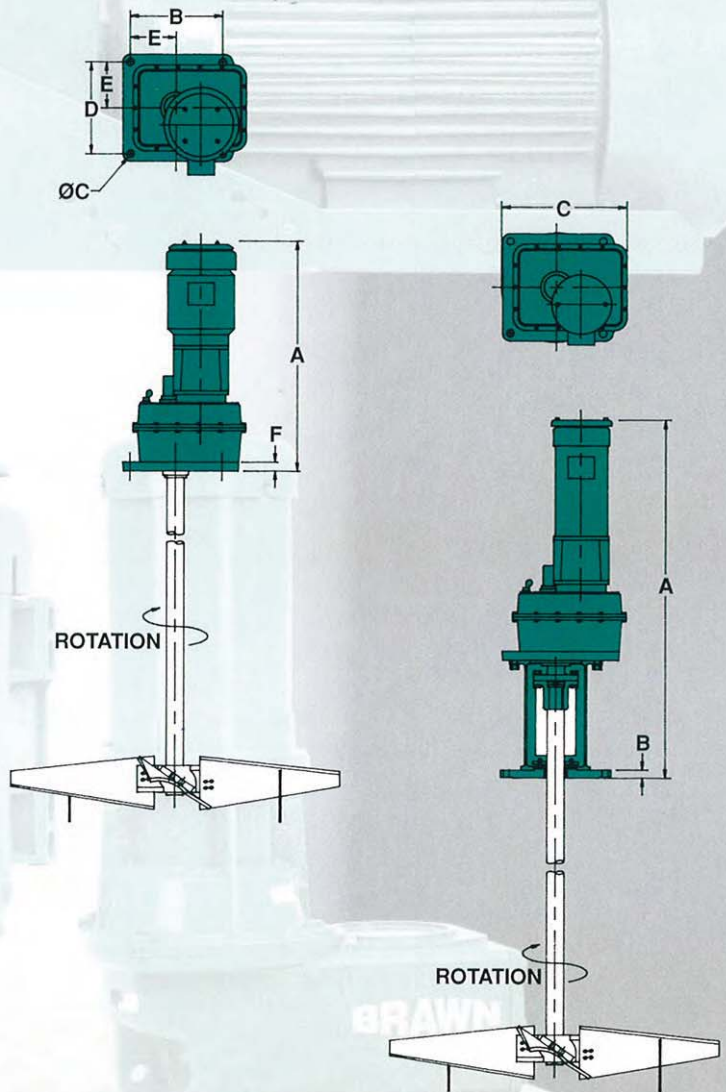

BTD SERIES / CLOSED TANK					
CASE SIZE	A	B	C	STD. ANSI FLANGE	BASIC WEIGHT*
20	49.0	1.4	16.1	8" 150 lbs.	340 lbs.
21	54.0	1.4	19.0	10" 150 lbs.	575 lbs.
22	59.0	1.4	21.3	10" 150 lbs.	675 lbs.

**BRAWN™**  
MIXER, INC.

\*Basic weight does not include motor, shaft or impellers.

# BRAWN™ MIXER, INC.

If your company has big process problems, or needs a solution that will be guaranteed, turn to BRAWN MIXER, INC. Brawn's depth of experience in mechanical design and process solutions increases your odds of getting satisfactory results with your big mixing problems.

Our drives meet all applicable AGMA and ASTM standards. Brawn's motor options are unparalleled due to the use of standard NEMA or IEC configurations.

At BRAWN MIXER, INC., we provide guaranteed solutions for your mixing problems.

## GUARANTEE:

*Brawn Mixer guarantees that in the case of failure due to faulty material or workmanship we will repair or replace the defective equipment for the first year after shipment. Furthermore, Brawn will provide in writing a guarantee corresponding exactly with that of any other mixer manufacturer's guarantee when presented with written verification and a purchase order for the corresponding mixer.*



MIXING SOLUTIONS



**BRAWN MIXER, INC.**

## Options

### Mechanical Seals

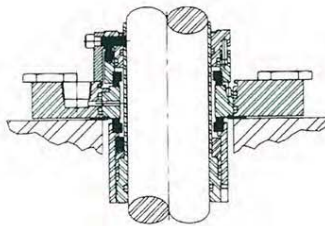
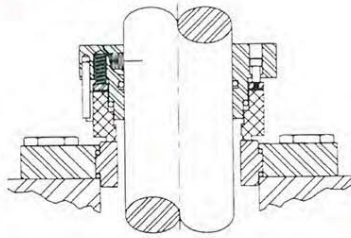

### Stuffing Boxes

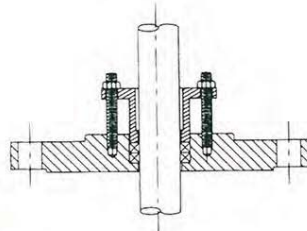
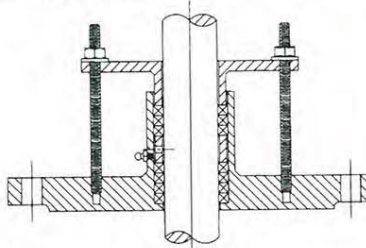

### Impellers

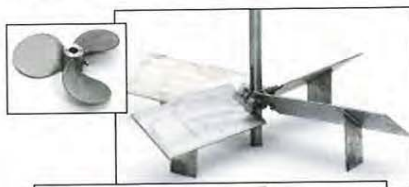

Your Representative:

## BRAWN Portable and Sanitary Mixers

• Innovation • Service • Quality • Value



*BRAWN makes a full line of mixers to meet all your mixing needs, including the all Stainless BRAWN Mixer, and custom orders. Call us for more information or a brochure.*

