

# COMPRESSED AIR COOLING | Air UPA Series

## COPPER TUBE CONSTRUCTION

### Features

- Full Line of Sizes and Features
- Energy Efficient
- High Performance
- Low flows to 100 CFM
- Horizontal or Vertical Air Flow
- Lightweight, may be Shipped UPS
- Ratings Based on Comprehensive Testing
- Attractive, Durable Baked Enamel Finish
- Floor or Suspended Mounting



Shown with optional moisture separators

### Ratings

**Maximum Operating Pressure** 250 PSIG

**Maximum Operating Temperature** 350° F

### Materials

**Cabinet** Steel with Baked Enamel Finish

**Core** Aluminum Fins on Copper Tubes

**Fan** Heavy Gauge Aluminum with Steel Hub

**Motor** Open Vented

**Fan Guard** Zinc Chromate Plated Steel

## How to Order

UPA

-

Model Series  
UPA

Model Size  
Selected



# Dimensions

## Models UPA-20 & UPA-35

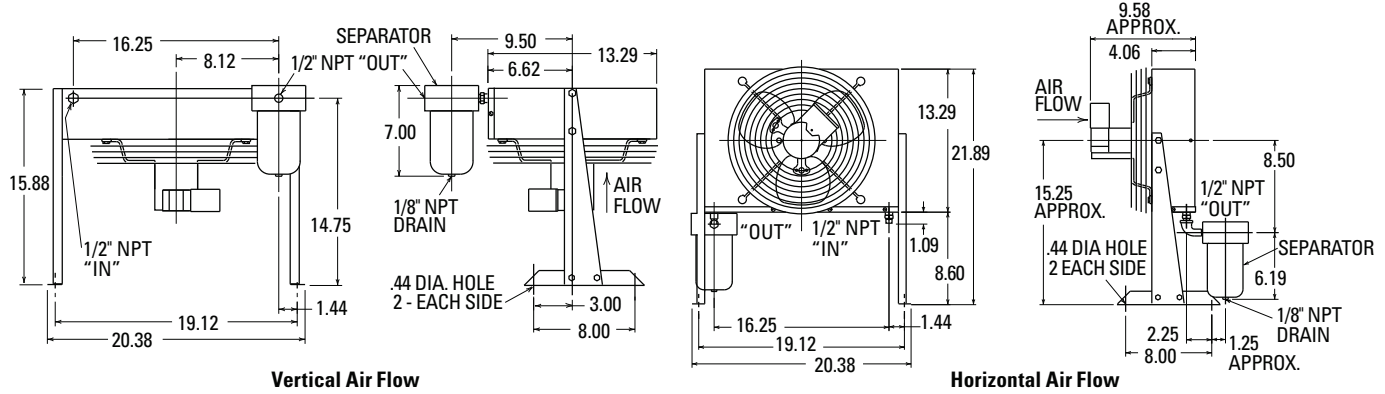

## Models UPA-50 & UPA-100

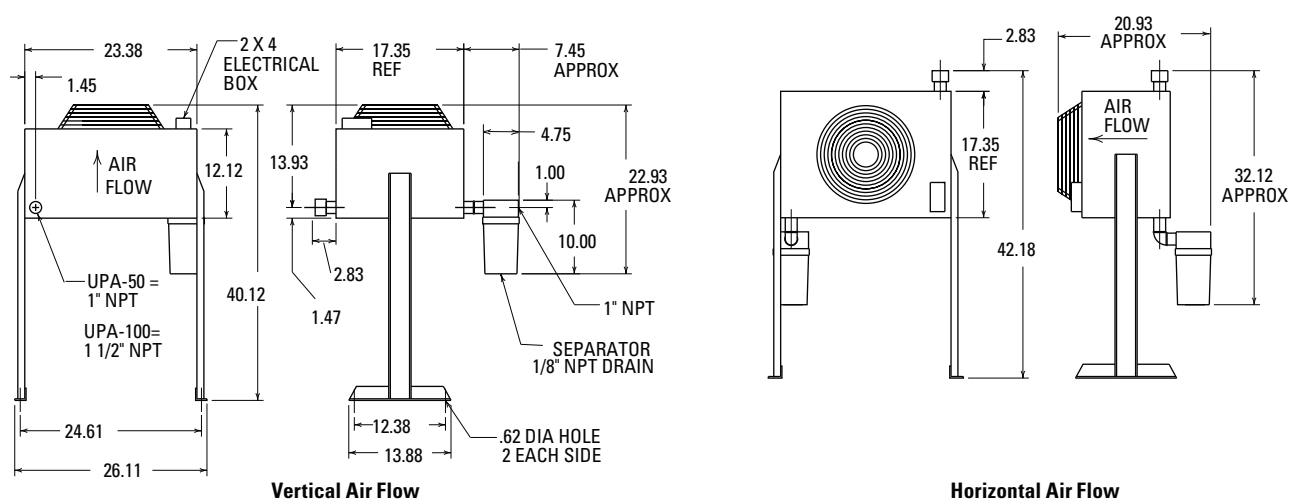

Note: We reserve the right to make reasonable design changes without notice. All dimensions are in inches.

## Capacity Selection Chart Max. SCFM @ 5, 10, 15 and 20°F Approach

Inlet Temp. °F	150				200				250				300				350				Recommended Optional Separator Model Number	
	5	10	15	20	5	10	15	20	5	10	15	20	5	10	15	20	5	10	15	20		
Model Number	UPA-20	17	35*	35*	35*	11	22	35	35*	8	16	20	35	6	12	19	26	5	10	15	21	S-50M or AD
	UPA-35	29	43*	43*	43*	17	36	43*	43*	12	27	35	42*	10	20	31	42*	8	16	26	35	
	UPA-50	43	72	72*	72*	28	50	70	72*	22	35	50	70	18	32	45	57	15	28	39	50	S-100M or AD
	UPA-100	95	125*	125*	125*	66	111	125*	125*	52	88	100	125*	44	74	100	125	38	64	86	108	

Above specifications are based on 80 to 125 PSIG operating pressures. Maximum pressure drop, less than 3 psi.  
 A flexible metal hose must be properly installed between the compressor and aftercooler to validate warranty.  
 \*Maximum ratings restricted by pressure drop, actual thermal capacities are higher.

## Electric Motor & Fan Data

Model	Fan CFM	Motor H.P.	Voltage	Phase	Full Load Amps	Hz	RPM	Nema Frame	Thermal Overload	Approx. Shipping Weight (Lbs.)
UPA-20	615	1/12	115/230	1	2.4/1.2	60	1550	Custom	Yes	25
UPA-35										27
UPA-50	945				61					
UPA-100					67					

Published electrical ratings are approximate, and may vary because of motor brand. Actual ratings are on motor nameplate.