

# FLUID COOLING | Shell & Tube C & SSC Series

## COPPER/STEEL OR STAINLESS STEEL CONSTRUCTION

### Features

- API/BASCO Interchange
- ASME Code Option
- Preferred for New Oil-Water Applications
- C-Series / SSC Series
- Rugged Steel Construction
- Low Cost
- Type 316 Stainless Steel Construction Optional
- Custom Designs Available
- Competitively Priced
- Optional Material Construction on C-Series: Tubes, Tubesheets, End Bonnets
- NPT, SAE O-Ring, SAE Flange, or BSPP Shell Side Connections Available
- End Bonnets Removable for Servicing
- Mounting Feet Included (May be rotated in 90° increments)



### Ratings Standard

- Maximum Shell Pressure** 300 psi
- Maximum Tube Side Pressure** 150 psi
- Maximum Temperature** 300°F

### Ratings ASME Code

- Maximum Shell Pressure** 300 psi
- Maximum Tube Side Pressure** 150 psi
- ASME Code SSC-1700** 200 psi
- Maximum Temperature** 300°F

### Materials C Series

- Tubes** Copper
- Headers** Steel
- Shell** Steel
- Shell Connections** Steel
- Baffles** Brass
- End Bonnets** Cast Iron
- Mounting Brackets** Steel
- Gaskets** Nitrile Rubber/Cellulose Fiber
- Nameplate** Aluminum Foil

### Materials SSC Series

- Tubes** 316 Stainless Steel
- Tubesheets** 316 L Stainless Steel
- Shell** 316 L Stainless Steel
- Shell Connections** 316 L Stainless Steel
- Baffles** 316 Stainless Steel
- End Bonnets** 316 Stainless Steel
- Mounting Brackets** Mild Steel
- Gaskets** Nitrile Rubber/Cellulose Fiber
- Nameplate** Aluminum Foil

## How to Order

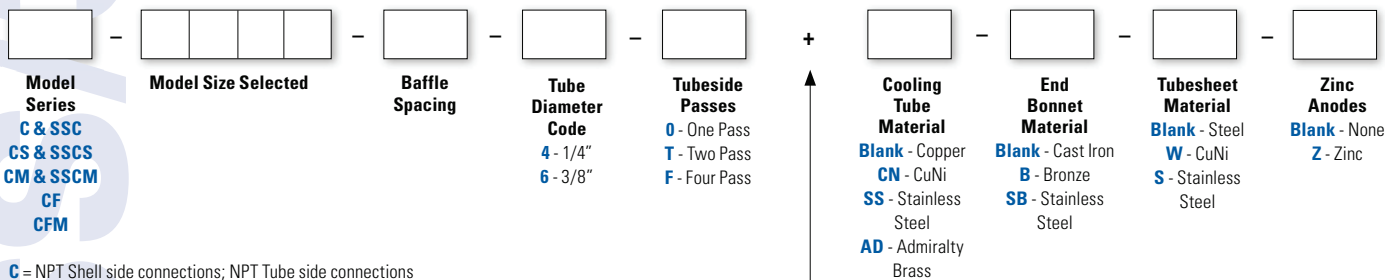

- C** = NPT Shell side connections; NPT Tube side connections
- CS** = SAE O-Ring Shell side connections; NPT Tube side connections
- CM** = BSPP Shell side connections; BSPP Tube side connections
- CF** = SAE Flange (with UNC threads) Shell side connections; NPT Tube side connections
- CFM** = SAE Flange (with Metric threads) Shell side connections; BSPP Tube side connections
- SSC** = NPT Shell side connections; NPT Tube side connections
- SSCS** = SAE O-Ring Shell side connections; NPT Tube side connections
- SSCM** = BSPP Shell side connections; BSPP Tube side connections

**ADD FOR C, CS, CM, CF and CFM MODELS ONLY:**  
Cooling tube material, end bonnet material, tubesheet material & zinc anodes

Consult factory for ASME Code

# Dimensions

## One Pass

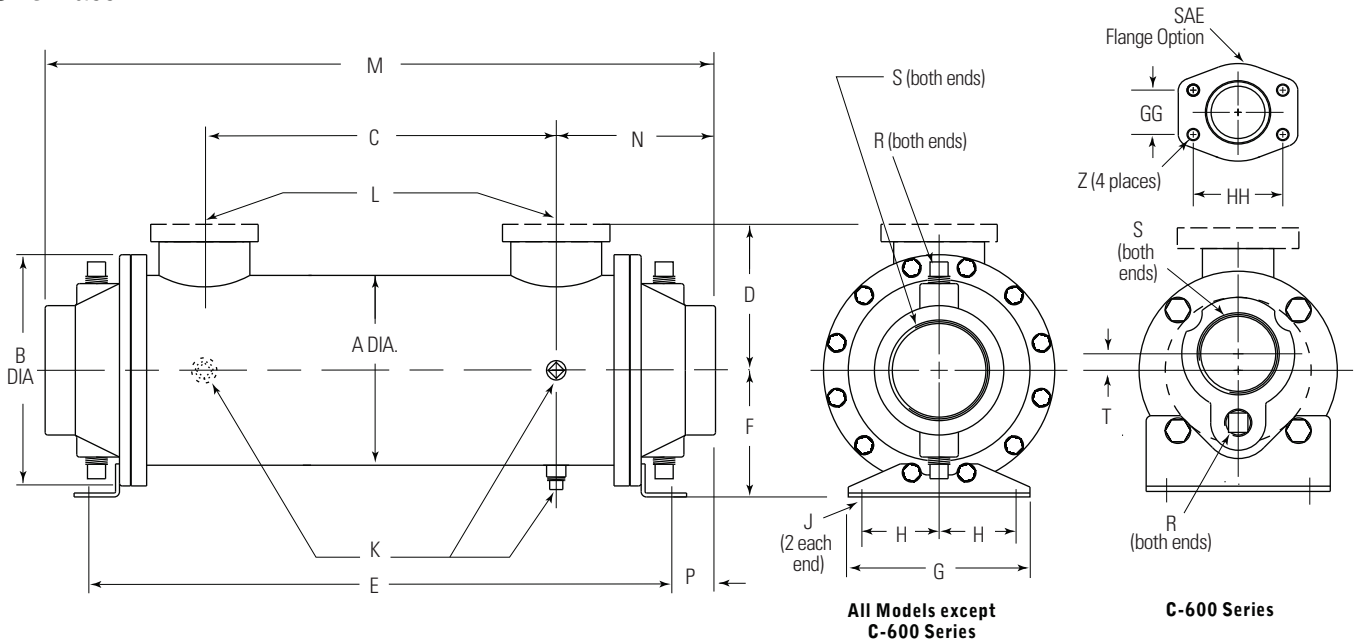

Flange Size	GG	HH	Z - CF	Z - CFM
1	1.03	2.06	3/8-16 UNC	M-10
1.50	1.41	2.75	1/2-13 UNC	M-12
2	1.69	3.06		
3	2.44	4.19	5/8-11 UNC	M-16

MODEL SIZE	A	B	C	D		E	F	G	H	J	K NPT	L		M	N	P	R NPT	S NPT/BSPP	T
				NPT/BSPP SAE O-RING	SAE FLANGE							NPT/BSPP FLANGE	SAE O-RING						
614	3.25	4.50	10.00	2.62	2.88	16.38	2.75	4.18	1.62	.44	(3)	1.00	#16 1 <sup>9</sup> / <sub>16</sub> -12 UNF-2B	17.18	3.59	.40	(2)	1.50	.38
624			20.00			26.38								27.18					
814	4.25	6.00	9.00	3.25	3.50	16.62	3.50	4.25	1.75	.50	(3)	1.50	#24 1 <sup>7</sup> / <sub>8</sub> -12 UN-2B	17.88	5.05	.92	(4)	2.00	—
824			19.00			26.62								27.88					
836			31.00			38.62								39.88					
1014			9.00			17.12								19.09					
1024	5.25	6.75	19.00	3.75	4.00	27.12	4.00	5.25	2.00	.75	(3)	2.00	#32 2 <sup>1</sup> / <sub>2</sub> -12 UN-2B	29.09	5.87	1.43	(4)	3.00	—
1036			31.00			39.12								41.09					
1224	6.25	7.75	18.25	4.25	4.88	27.13	4.50	6.25	2.50	.50	(3)	2.00	#32 2 <sup>1</sup> / <sub>2</sub> -12 UN-2B	30.00	7.23	1.99	(4)	3.00	—
1236			30.25			39.13								42.00					
1248			42.25			51.13								54.00					
1260			54.25			63.13								66.00					
1724	8.62	10.50	17.00	5.84	6.81	27.50	5.75	8.25	3.50	.62	(3)	3.00	—	31.47	7.23	1.99	(4)	4.00	—
1736			29.00			39.50								43.47					
1748			41.00			51.50								55.47					
1760			53.00			63.50								67.47					
1772			65.00			75.50								79.47					

NOTE: We reserve the right to make reasonable design changes without notice. Consult factory. All dimensions are inches.

# Dimensions

## Two Pass

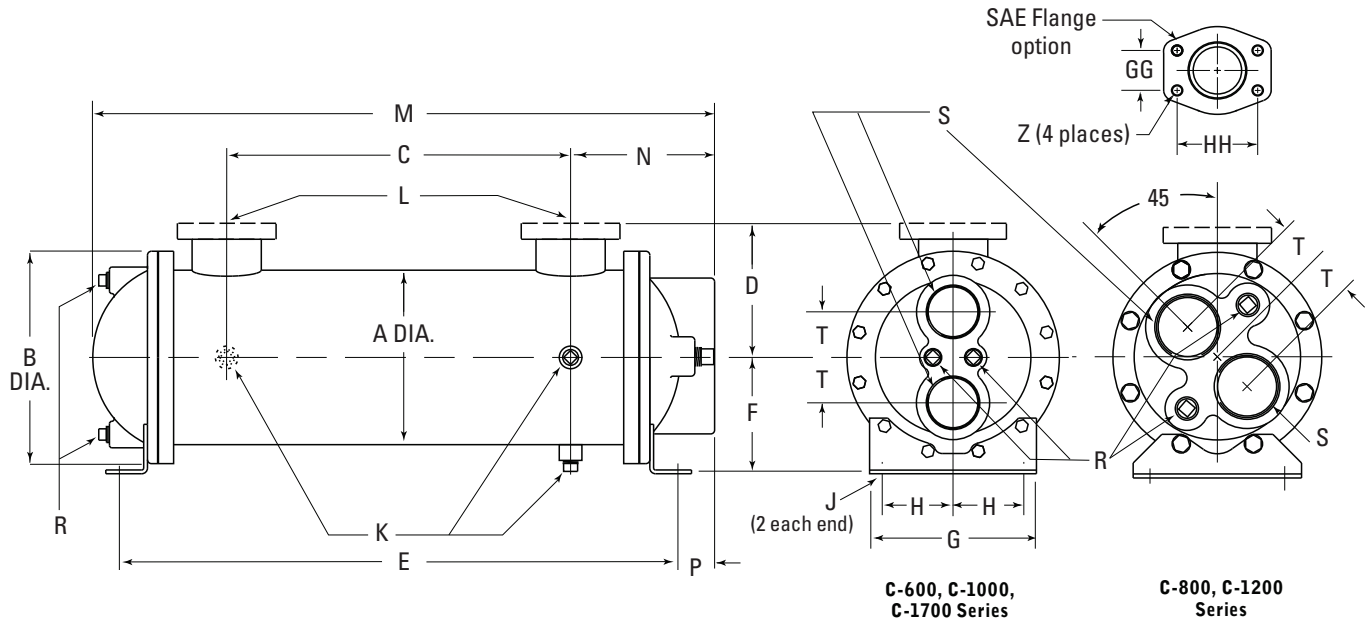

Flange Size	GG	HH	Z - CF	Z - CFM
1	1.03	2.06	3/8-16 UNC	M-10
1.50	1.41	2.75	1/2-13 UNC	M-12
2	1.69	3.06		
3	2.44	4.19	5/8-11 UNC	M-16

MODEL SIZE	A	B	C	D		E	F	G	H	J	K NPT	L		M	N	P	R NPT	S NPT/BSPP	T
				NPT/BSPP SAE O-RING	SAE FLANGE							NPT/BSPP FLANGE	SAE O-RING						
614	3.25	4.50	10.00	2.62	2.88	16.38	2.75	4.18	1.62	.44	(3)	1.00	#16 1 <sup>5</sup> / <sub>16</sub> -12 UNF-2B	17.12	3.56	.38	(2)	1.00	1.00
624			20.00			26.38								27.12					
814	4.25	6.00	9.00	3.25	3.50	16.62	3.50	4.25	1.75	.50	(3)	1.50	#24 1 <sup>7</sup> / <sub>8</sub> -12 UN-2B	17.88	4.44	.63	.38	1.25	1.06
824			19.00			26.62								27.88					
836			31.00			38.62								39.88					
1014			9.00			17.12								18.62					
1024	5.25	6.75	19.00	3.75	4.00	27.12	4.00	5.25	2.00	.50	(3)	2.00	#32 2 <sup>1</sup> / <sub>2</sub> -12 UN-2B	28.62	5.00	.94	(4)	1.50	1.50
1036			31.00			39.12								40.62					
1224	6.25	7.75	18.25	4.25	4.88	27.13	4.50	6.25	2.50	.75	(3)	2.00	#32 2 <sup>1</sup> / <sub>2</sub> -12 UN-2B	29.02	5.43	1.00	(4)	2.00	1.56
1236			30.25			39.13								41.03					
1248			42.25			51.13								53.03					
1260			54.25			63.13								65.03					
1724	8.62	10.50	17.00	5.84	6.81	27.50	5.75	8.25	3.50	.88	(3)	3.00	-	30.62	7.06	1.81	(4)	2.50	2.25
1736			29.00			39.50								42.62					
1748			41.00			51.50								54.62					
1760			53.00			63.50								66.62					
1772			65.00			75.50								78.62					

NOTE: We reserve the right to make reasonable design changes without notice. Consult factory. All dimensions are inches.

# Dimensions

## Four Pass

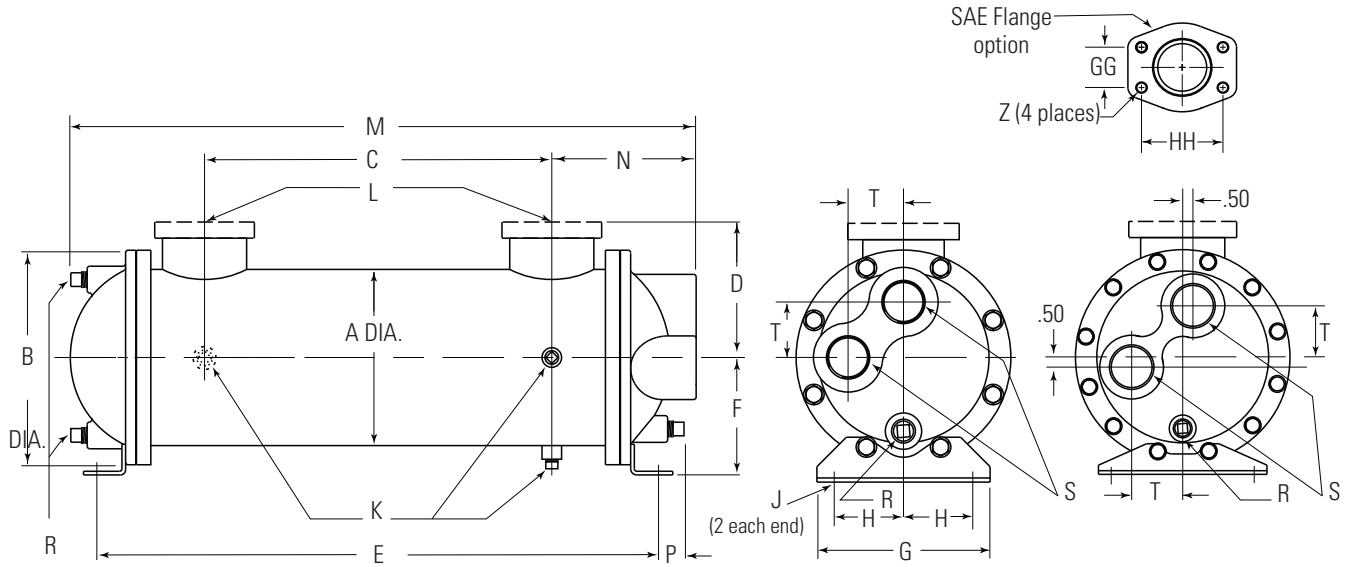

All Models except C-1700 Series

C-1700 Series

Flange Size	GG	HH	Z - CF	Z - CFM
1	1.03	2.06	3/8-16 UNC	M-10
1.50	1.41	2.75	1/2-13 UNC	M-12
2	1.69	3.06		
3	2.44	4.19	5/8-11 UNC	M-16

MODEL SIZE	A	B	C	D		E	F	G	H	J	K NPT	L		M	N	P	R NPT	S NPT/BSPP	T	
				NPT/BSPP SAE O-RING	SAE FLANGE							NPT/BSPP FLANGE	SAE O-RING							
614	3.25	4.50	10.00	2.62	2.88	16.38	2.75	4.18	1.62	.44	(3)	1.00	#16 15/16-12 UNF-2B	17.12	3.56	.38	(2)	.38	1.00	
624			20.00			26.38								27.12						
814	4.25	6.00	9.00	3.25	3.50	16.62	3.50	4.25	1.75	.44	(3)	1.50	#24 17/8-12 UN-2B	17.88	4.44	.63	(3)	.75	1.25	
824			19.00			26.62								27.88						
836			31.00			38.62								39.88						
1014	5.25	6.75	9.00	3.75	4.00	17.12	4.00	5.25	2.00	.50	(3)	2.00	#32 2 1/2-12 UN-2B	18.81	4.81	.75	(3)	1.00	1.69	
1024			19.00			27.12								28.81						
1036			31.00			39.12				.75				40.81						
1224	6.25	7.75	18.25	4.25	4.88	27.13	4.50	6.25	2.50	.50	(3)	2.00	#32 2 1/2-12 UN-2B	29.13	5.44	1.00	(3)	.38	1.50	2.00
1236			30.25			39.13								41.13						
1248			42.25			51.13								53.13						
1260			54.25			63.13								65.13						
1724	8.62	10.50	17.00	5.84	6.81	27.50	5.75	8.25	3.50	.62	(3)	3.00	-	29.86	7.06	1.81	(3)	2.00	2.50	
1736			29.00			39.50								41.86						
1748			41.00			51.50								53.86						
1760			53.00			63.50								65.86						
1772			65.00			75.50								77.86						

NOTE: We reserve the right to make reasonable design changes without notice. Consult factory. All dimensions are inches.

# Performance Curves

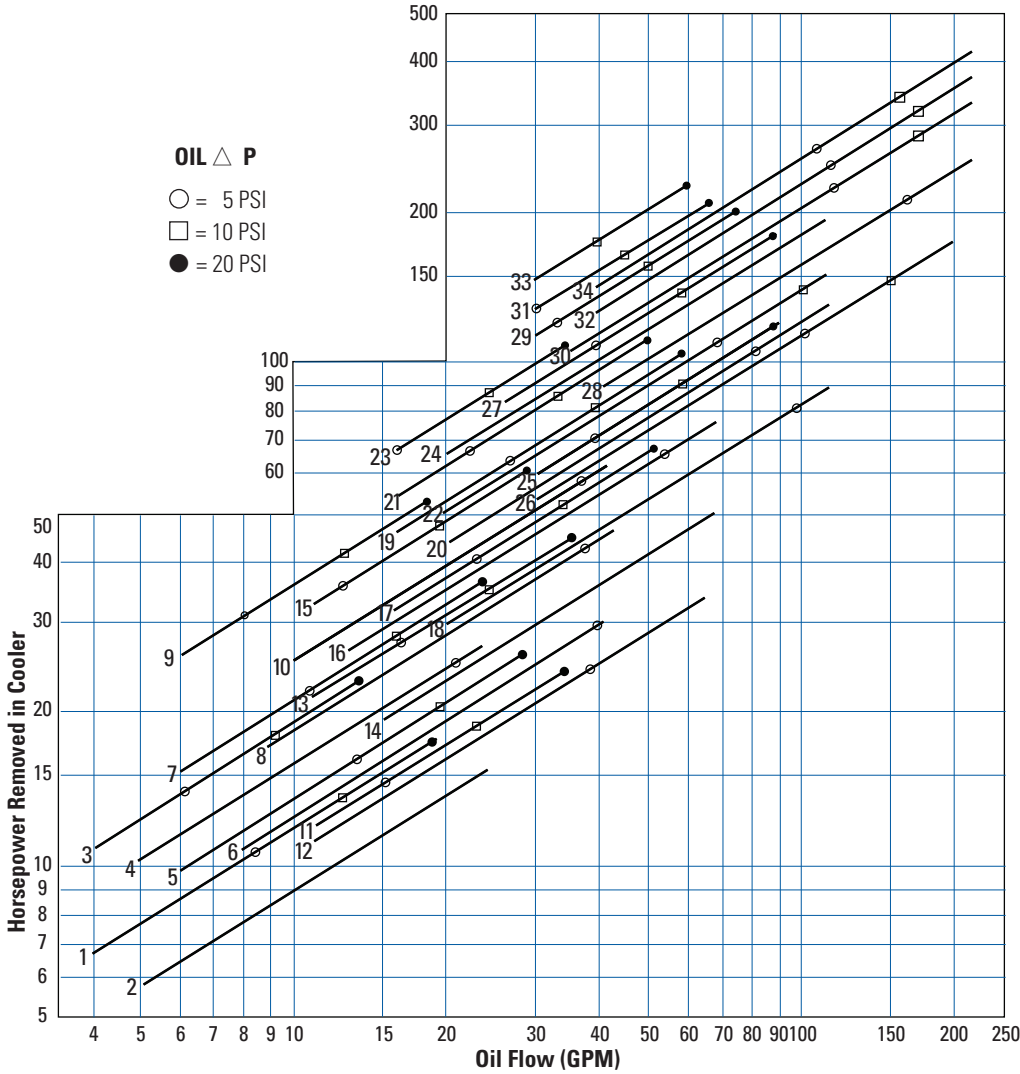

Model	Ship Wt. (lbs)
1. C/SSC-614-1.3-4-F	17
2. C/SSC-614-3-4-F	17
3. C/SSC-624-1.3-4-F	24
4. C/SSC-624-3-4-F	24
5. C/SSC-814-1.7-4-F	32
6. C/SSC-814-4-4-F	32
7. C/SSC-824-1.7-4-F	41
8. C/SSC-824-4-4-F	41
9. C/SSC-836-1.7-4-F	53
10. C/SSC-836-4-4-F	53
11. C/SSC-1014-2-6-F	43
12. C/SSC-1014-5-6-F	43
13. C/SSC-1024-2-6-F	57
14. C/SSC-1024-5-6-F	57
15. C/SSC-1036-2-6-F	72
16. C/SSC-1036-5-6-F	72
17. C/SSC-1224-2.5-6-F	85
18. C/SSC-1224-6-6-F	85
19. C/SSC-1236-2.5-6-F	110
20. C/SSC-1236-6-6-F	110
21. C/SSC-1248-2.5-6-F	135
22. C/SSC-1248-6-6-F	135
23. C/SSC-1260-2.5-6-F	160
24. C/SSC-1260-6-6-F	160
25. C/SSC-1724-3.5-6-F	140
26. C/SSC-1724-8.4-6-F	140
27. C/SSC-1736-3.5-6-F	180
28. C/SSC-1736-8.4-6-F	180
29. C/SSC-1748-3.5-6-F	220
30. C/SSC-1748-8.4-6-F	220
31. C/SSC-1760-3.5-6-F	260
32. C/SSC-1760-8.4-6-F	260
33. C/SSC-1772-3.5-6-F	300
34. C/SSC-1772-8.4-6-F	300

\*Shipping Weights are approximate

WATER COOLED  
C & SSC

C/SSC

# Selection Procedure

Performance Curves are based on 100SSU oil leaving the cooler 40°F higher than the incoming water temperature (40°F approach temperature). Curves are based on a 2:1 oil to water ratio.

**Step 1 Determine the Heat Load.** This will vary with different systems, but typically coolers are sized to remove 25 to 50% of the input nameplate horsepower. (Example: 100 HP Power Unit x .33 = 33 HP Heat load.)

$$\text{If BTU/Hr. is known: } \text{HP} = \frac{\text{BTU/Hr}}{2545}$$

**Step 2 Determine Approach Temperature.**

$$\text{Desired oil leaving cooler } ^\circ\text{F} - \text{Water Inlet temp. } ^\circ\text{F} = \frac{\text{Actual}}{\text{Approach}}$$

**Step 3 Determine Curve Horsepower Heat Load.** Enter the information from above:

$$\text{HP heat load} \times \frac{40}{\text{Actual Approach}} \times \frac{\text{Viscosity}}{\text{Correction A}} = \text{Curve Horsepower}$$

**Step 4 Enter curves** at oil flow through cooler and curve horsepower. Any curve above the intersecting point will work.

**Step 5 Determine Oil Pressure Drop from Curves.** Multiply pressure drop from curve by correction factor B found on oil viscosity correction curve.

● = 5 PSI; ■ = 10 PSI; ▲ = 20 PSI; + = 40 PSI.

## Oil Temperature

Oil coolers can be selected by using entering or leaving oil temperatures.

Typical operating temperature ranges are:

Hydraulic Motor Oil	110°F - 130°F
Hydrostatic Drive Oil	130°F - 180°F
Lube Oil Circuits	110°F - 130°F
Automatic Transmission Fluid	200°F - 300°F

## Desired Reservoir Temperature

**Return Line Cooling:** Desired temperature is the oil temperature leaving the cooler. This will be the same temperature that will be found in the reservoir.

**Off-Line Recirculation Cooling Loop:** Desired temperature is the temperature entering the cooler. In this case, the oil temperature change must be determined so that the actual oil leaving temperature can be found. Calculate the oil temperature change (Oil ΔT) with this formula:

$$\text{Oil } \Delta T = (\text{BTU's/Hr.}) / (\text{GPM Oil Flow} \times 210)$$

To calculate the oil leaving temperature from the cooler, use this formula:

$$\text{Oil Leaving Temperature} = \text{Oil Entering Temperature} - \text{Oil } \Delta T$$

This formula may also be used in any application where the only temperature available is the entering oil temperature.

**Oil Pressure Drop:** Most systems can tolerate a pressure drop through the heat exchanger of 20 to 30 PSI. Excessive pressure drop should be avoided. Care should be taken to limit pressure drop to 5 PSI or less for case drain applications where high back pressure may damage the pump shaft seals.

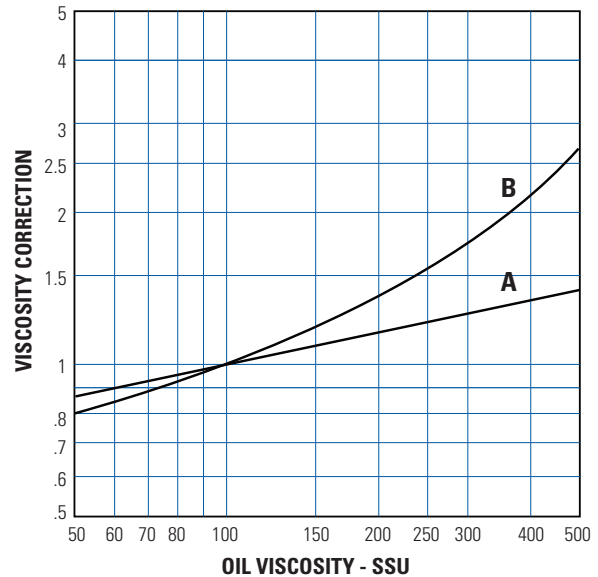

## Maximum Flow Rates

Example Model No.

C/SSC - 1024 - 2 - 6 - F

Unit Size	Baffle Spacing	Shell Side (GPM)	Tube Side (GPM)		
			O	T	F
600	1.3, 3	19, 29	48	24	12
800	1.7, 4	32, 69	84	42	21
1000	2, 5	41, 69	146	73	37
1200	2.5, 6	60, 115	224	112	56
1700	3.5, 8.4	125, 253	465	232	116

### Exceptions to Maximum Shell Side Flows

C/SSC-814-4-4-*	63 GPM Max.
C/SSC-1014-2-6-*	33 GPM Max.
C/SSC-1014-5-6-*	66 GPM Max.
C/SSC-1724-3.5-6-*	105 GPM Max.
C/SSC-1724-8.4-6-*	200 GPM Max.

**Caution:** Incorrect installation can cause this product to fail prematurely, causing the shell side and tube side fluids to intermix.

## Piping Hook-up

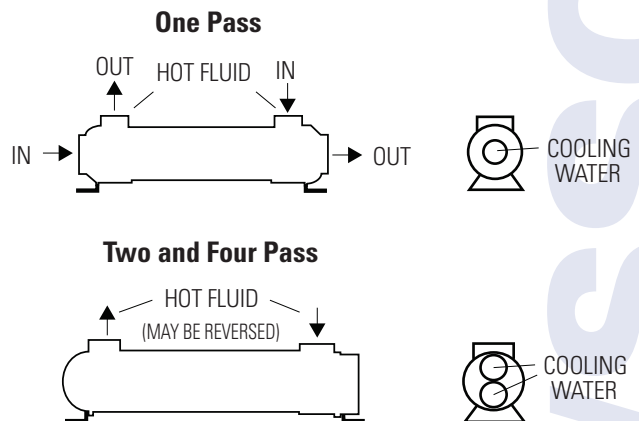

Specific applications may have different piping arrangements. Contact factory for assistance.