

COMPRESSED AIR COOLING | Air ACOC/ACOCH Series

BRAZED ALUMINUM CONSTRUCTION

Features

- **Combination Welded Cores – Air & Oil Core**
- **Brazed Aluminum Core/Bar and Plate**
- **Excellent for Field Conversions**
- **Vertical Air Flow**
- **Compact Design**
- **Light Weight**
- Compact, high performance all aluminum core assembly
- Designed specifically for rotary screw compressors
- Ideal for converting water cooled units to air cooled
- Eliminates high water and sewer costs
- Eliminates corrosion problems associated with water cooled units
- Vertical air flow works well for heat recovery
- State-of-the-art heat transfer technology
- Detachable Legs (ACOC) Shipped Unattached
Fixed Mounting Feet on ACOCH

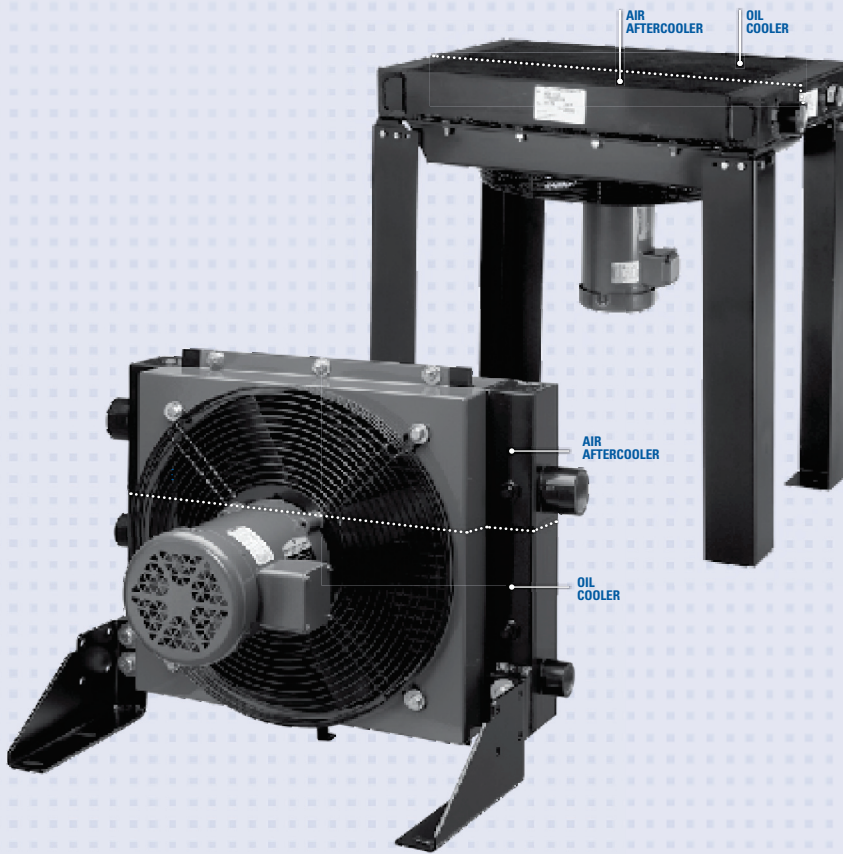

Ratings

Maximum Operating Pressure 250 psi
Maximum Operating Temperature 350°F

Materials

Legs Steel with Baked Enamel Finish
Shroud Steel
Core Brazed Aluminum Bar and Plate
Fan Aluminum Hub, Plastic Blades
Motor TEFC

How to Order

ACOC		
Model Series ACOC	Model Size Selected 400 725 950 1200 1600 2000 2500 3000 3500	Specify Motor Required 0 - No Motor (includes Fan Blade & Fan Guard) 2 - Single Phase 3 - Three Phase 6 - 575 Volt

ACOCH		
Model Series ACOCH	Model Size Selected 400 725 950 1200 1600 2000	Specify Motor Required 0 - No Motor (includes Fan Blade & Fan Guard) 2 - Single Phase 3 - Three Phase 6 - 575 Volt



Dimensions

ACOC – Vertical Air Flow

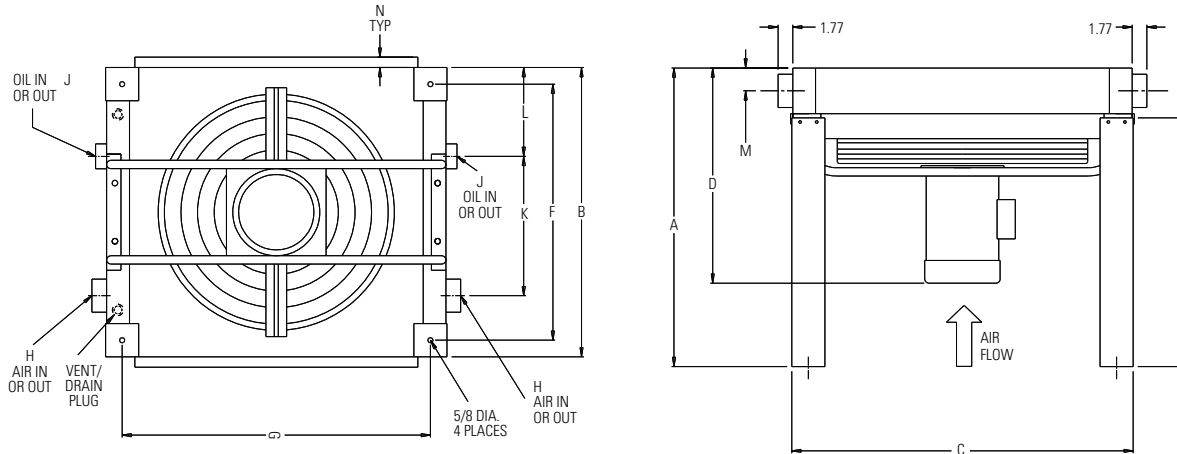

Model	A	B	C	D Approx	E	F	G	H NPT	J NPT	K	L	M	N
ACOC-400	34.20	17.96	22.68	20.86	30.00	13.96	18.68	1.50	1.00	8.35	5.08	1.85	1.25
ACOC-725	34.20	22.37	30.56	20.86	30.00	18.37	26.56	1.50	1.00	10.55	6.34	1.85	1.25
ACOC-950	36.01	26.78	37.24	23.62	30.00	22.78	33.24	2.00	1.25	12.67	7.64	2.76	1.25
ACOC-1200	36.01	26.78	41.19	25.51	30.00	22.78	37.19	2.00	1.25	12.83	7.64	2.76	1.25
ACOC-1600	36.01	34.89	41.19	27.51	30.00	30.89	37.19	2.50	1.50	16.81	10.08	2.76	1.25
ACOC-2000	36.01	37.88	51.04	28.51	30.00	33.88	47.04	2.50	1.50	18.47	10.98	2.76	1.25
ACOC-2500	36.01	43.70	49.07	28.51	30.00	39.70	45.07	3.00	2.00	21.11	12.83	2.76	1.25
ACOC-3000	36.01	52.52	51.04	30.51	30.00	48.52	47.04	3.00	2.00	33.30	8.00	2.76	1.25
ACOC-3500	36.01	56.30	51.04	30.51	30.00	52.30	47.04	4.00	2.50	27.40	18.43	2.76	1.25

Note: We reserve the right to make reasonable design changes without notice. All Dimensions are in inches.

ACOCH – Horizontal Air Flow

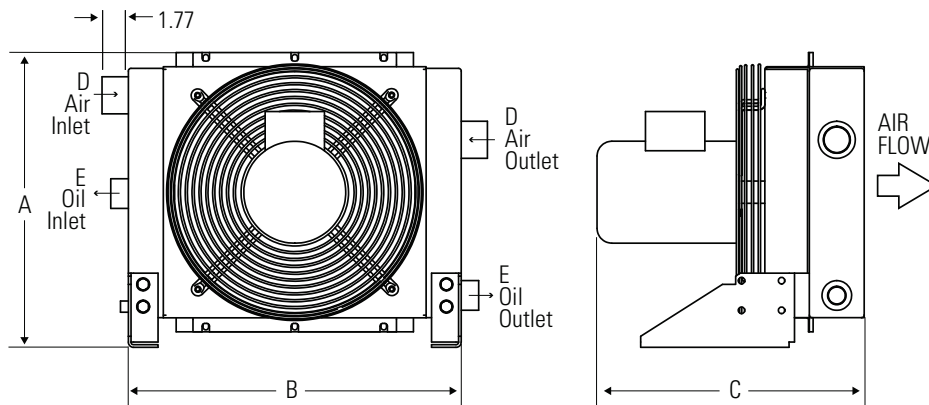

Model	A	B	C Approx.	D NPT	E NPT
ACOCH-400	19.88	22.45	20.86	1.50	1.00
ACOCH-725	24.37	30.56	20.86	1.50	1.00
ACOCH-950	28.82	37.24	23.62	2.00	1.25
ACOCH-1200	28.82	41.19	25.51	2.00	1.25
ACOCH-1600	36.89	41.19	27.51	2.50	1.50
ACOCH-2000	39.53	50.79	28.51	2.50	1.50

Note: We reserve the right to make reasonable design changes without notice. All Dimensions are in inches.

Selection Procedure

Step 1 Determine the Air Compressor's motor horsepower.

Step 2 Enter the chart at the motor horsepower to select the correct model.

Step 3 Check the aftercooler SCFM. The SCFM of air discharged from the air compressor must be equal to or less than the value in the chart for the model selected. If it is not, choose a larger model. If the SCFM is unknown, multiply the air compressor's motor horsepower by 4.5 to determine the SCFM capacity required.

Model	Compressor H.P.	Aftercooler Maximum SCFM with 100 PSI Air & A 15°F Approach Temperature
ACOC(H)-400	15-35	175
ACOC (H)-725	40-55	275
ACOC (H)-950	60-85	425
ACOC (H)-1200	90-120	600
ACOC (H)-1600	125-155	775
ACOC (H)-2000	160-225	1125
ACOC-2500	230-275	1375
ACOC-3000	280-325	1625
ACOC-3500	330-360	1800

Sizing

- Oil flow is .45 GPM/HP.
- Oil pressure drop - 15 psi or less
- Oil heat transfer based on 100°F E.T.D.
(E.T.D. = Entering Temperature Difference)
(E.T.D. = Oil in Temperature - Ambient Air Temperature)
- Air aftercooler pressure drop - 3 psi or less.
- E.T.D. Temperature Correction Factor:

$$HP_{\text{chart}} = HP_{\text{compressor}} \times \frac{100}{\text{Desired E.T.D.}}$$

Recommended Typical Installation

- Support piping as needed. Flexible connectors must be properly installed to validate warranty.
- Coolers should not operate in ambient temperatures below 35°F (1°C). Consult factory for recommendations.
- The fan cannot be cycled.
- AHP coolers operated outdoors must be protected from weather. Consult factory for recommendations.
- If ductwork or additional static resistance is added to the cooler airstream, an auxiliary air mover may be required.

Maintenance

Periodic cleaning of the fins with compressed air is needed to remove the accumulation of dirt and dust. Check the automatic drain on the separator (not included) periodically.

If the inside of the tubes need to be cleaned of oil and carbon, use a chlorinated solvent. Do not use strong solvents. Do not use acids or caustic cleaners.

Electric Motor and Fan Data

Model	Fan CFM	Motor H.P.	Voltage	Phase	Full Load Amps 230V	Hz	RPM	Nema Frame	Thermal Over-load	Net Weight Lbs.	Approx. Shipping Wt. (Lbs.)
ACOC(H)-400	2200 1825/2200	1.0	115/208-230 208-230/460 ⁽²⁾	1 3	6.0 3.6/3.2	60 ⁽¹⁾ 50/60	3450 2850/3450	56C	No	105	136
ACOC(H)-725	3600 3025/3600	1.5	115/208-230 208-230/460 ⁽³⁾	1 3	8.5 4.8/4.2	60 ⁽¹⁾ 50/60	3450 2850/3450			149	155
ACOC(H)-950	4700	1.5	115/208-230 208-230/460	1 3	8.6 4.6	60	1740	145TC		223	280
ACOC(H)-1200	7000	5.0	230	1	23.0			184TC		297	410
		3.0	208-230/460	3	8.8			182TC			
ACOC(H)-1600	9700	5.0	208-230/460	3	13.4			184TC		345	495
ACOC(H)-2000	11000	7.5	230/460		19.6			213TC		495	530
ACOC-2500	14000				24.8			215TC		522	540
ACOC-3000	17500	10.0			655			780			
ACOC-3500	17500			690	820						

All motors shown are TEFC—Other motor options available upon request.

Published electrical ratings are approximate and may vary because of motor brand. Actual ratings are on motor nameplate.

⁽¹⁾ May also be operated at 50 Hz. Consult factory for details.

⁽²⁾ 50 Hz voltage: 190 - 200 - 208 - 220/380 - 400 - 415 - 440

⁽³⁾ 50 Hz voltage: 190 - 208/380 - 415

Bottom view of cooler to illustrate piping

