



LECTRODRYER

ADSORPTION TECHNOLOGY EXPERTS

LANDFILL GAS COMPRESSION SYSTEM



EAST KENTUCKY POWER PENDELTON COUNTY LANDFILL GAS-TO-ENERGY PROJECT FALMOUTH, KENTUCKY



LANDFILL GAS COMPRESSION SYSTEM

SYSTEM DESCRIPTION

The Lectrodryer Landfill Gas Compression System is designed to compress, clean, and deliver a volume of landfill gas at a specified pressure and quality. The LGCS strives for efficiency, one that minimizes initial cost and seeks to operate at the lower possible horsepower. Lectrodryer's Landfill Gas Compression System is designed to meet customer specifications and can be installed indoors or outdoors.

COMPONENTS

The Landfill Gas Compression and Clean-up System consists of:

- Blower
- Electric Motors
- Oil Management System
- Automatic Suction Valve
- Suction Liquid Knockout Vessel
- Aftercooler
- Discharge Coalescing Gas Filter
- Scrubber
- Gas Reheat Exchanger
- Controls

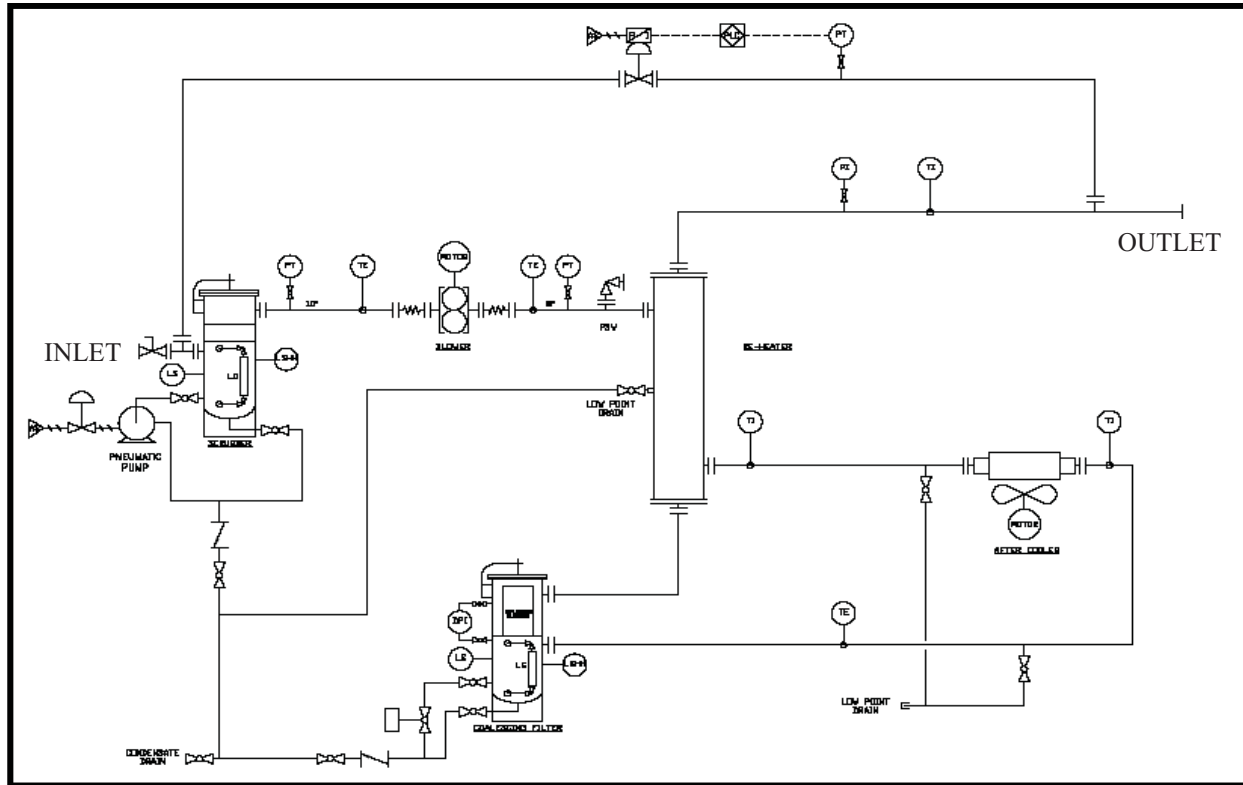

THERMAL PRODUCTS INC.

Corporate Office: 964A Route 146, Clifton Park, New York 12065. Phone 518-877-0231 Fax 518-877-3329

Eastern New England Office: Phone 978-567-7951 Fax 978-567-0817

Web Page: www.Thermalproducts.com

E-Mail: Sales@thermalProducts.com