

FLUID COOLING | Shell & Tube EKT Series

COPPER & STEEL CONSTRUCTION

Features

- HPU, In-tank Cooler
- Compact Size
- EK Style & Size
- High Efficiency Finned Bundle Design
- Serviceable
- Removable
- In-tank Design Minimizes Space Requirements and Reduces Plumbing
- Internal Aluminum Fins Dramatically Increase Performance
- Removable End Bonnets Allow Water Passage Servicing
- High Strength Steel Shell

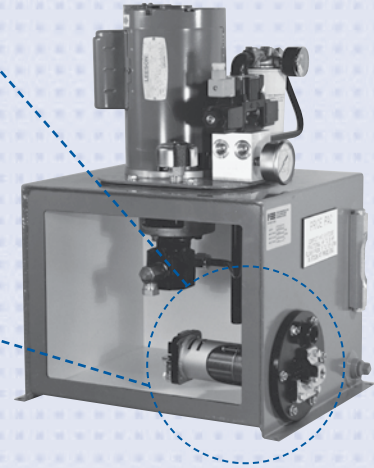
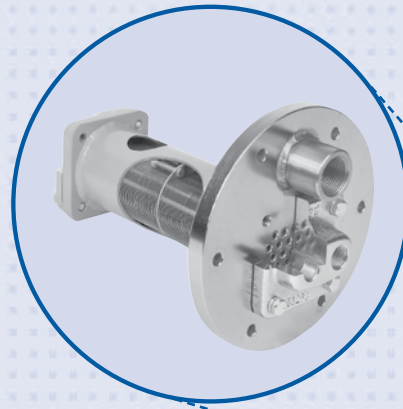

OPTIONS

- SAE or BSPP Connections Available
- Internal Oil Flow Bypass Relief (SURGE-CUSHION®)

Ratings

Operating Pressure:

Shellside 75 psi – Tubeside 150 psi

Test Pressure:

Shellside 75 psi – Tubeside 150 psi

Maximum Temperature 250° F

Materials

- Shell** Steel
- Tubes** Copper
- Fins** Aluminum
- Tubesheets** Steel
- Baffles** Steel
- End Bonnets** Cast Iron
- Gaskets** Nitrile Rubber/Cellulose Fiber

Surge-Cushion (Option)

The SURGE-CUSHION® is a protective device (patented) designed to internally bypass a portion of the oil flow during cold start conditions, or when sudden flow surges temporarily exceed the maximum flow allowed for a given cooler. This device may replace an external bypass valve, but it is not intended to bypass the total oil flow.

WATER COOLED EKT

How to Order

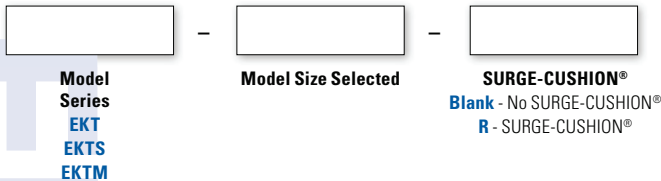

EKT = NPT Connections.
 EKTS = SAE Oil Connections.
 EKTM = All Metric Connections.



Dimensions

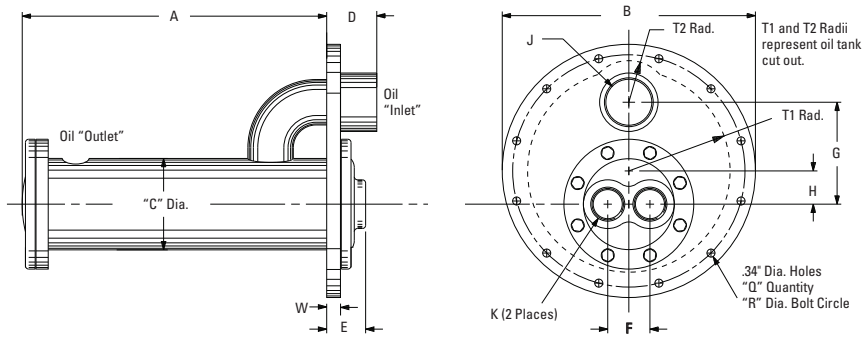

MODEL	A	B	C	D	E	F	G	H	J NPT or BSPF	J SAE	K NPT or BSPF	Q	R	T1	T2	W	Net. Wt.	Approx. Ship Wt.
EKT-508	8.87	6.79	2.55	1.84	1.68	1.12	2.44	.50	3/4"	#12	3/8"	6	5.60	2.25	.79	.62	11	14
EKT-518	18.87																14	16
EKT-708	8.72	9.75	3.52	2.22	1.67	1.62	3.94	1.25	1-1/2"	#24	3/4"	12	8.94	4.00	—	.70	23	27
EKT-718	18.72																30	34
EKT-1012	12.55	10.38	5.05	2.23	2.38	4.69	1.19				1"		9.62	4.38	1.12		42	46
EKT-1024	24.55																58	63

NOTE: We reserve the right to make reasonable design changes without notice. Certified drawings are available upon request. All dimensions in inches. Tank gasket is included. BSPP threads are 55° full form whitworth.

Selection Procedure

Performance Curves are based on a 40°F approach temperature, a 2:1 oil to water ratio and an average oil viscosity of 100 SSU. Example: oil leaving cooler at 125°F with 85°F cooling water (125°F - 85°F = 40°F). The 2:1 oil to water ratio means that for every GPM of oil circulated, a minimum of 1/2 GPM of water must be circulated to obtain the curve results.

Step 1 Corrections for approach temperature and oil viscosity.

$$HP_{\text{Heat Removed in Cooler}} = HP_{\text{Actual}} \times \left[\frac{40^\circ\text{F}}{\text{Oil out and } ^\circ\text{F} - \text{Water in } ^\circ\text{F}} \right] \times \text{Correction A}$$

Step 2 Oil Pressure Drop Coding: ● = 5 PSI; ■ = 10 PSI. Curves having no pressure drop symbol indicate that the oil pressure drop is less than 5 PSI to the highest oil flow rate for that curve. Multiply curve oil pressure drop by Correction B.

Viscosity Corrections

Average Oil SSU	A	B
50	0.84	0.6
100	1.0	1.0
200	1.14	2.0
300	1.24	3.1
400	1.31	4.1
500	1.37	5.1

Maximum Flow Rates

Unit Size	Shell Side (GPM)	Tube Side (GPM)
500	20	6
700	60	12
1000	80	28

If maximum allowable flow rates are exceeded, premature failure may occur.

Performance Curves

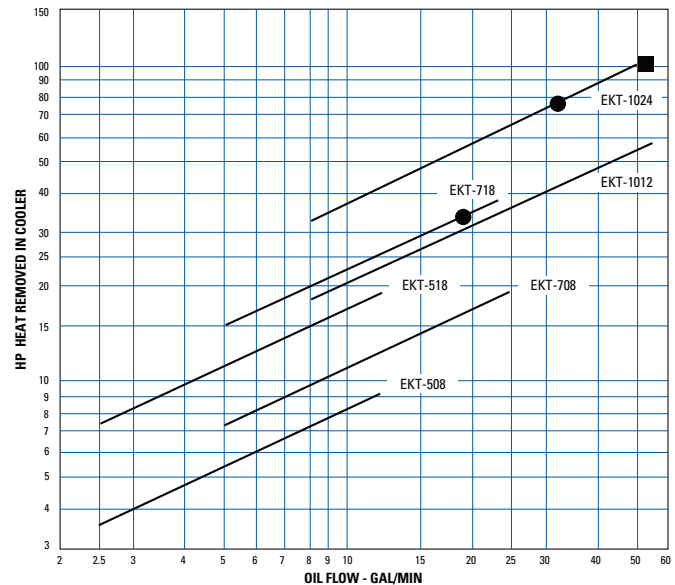

WATER COOLED EKT