



Thermostatic Control Valves

Model C

Typical applications

- Lubricating oil temperature control
- Jacket temperature (HT)
- Secondary water low temperature (LT)
- Heat recovery
- Water saving applications
- Boiler inlet temperature control
- Co-generation, cooling towers
- Temperature mixing or diverting
- Engine and compressor cooling system

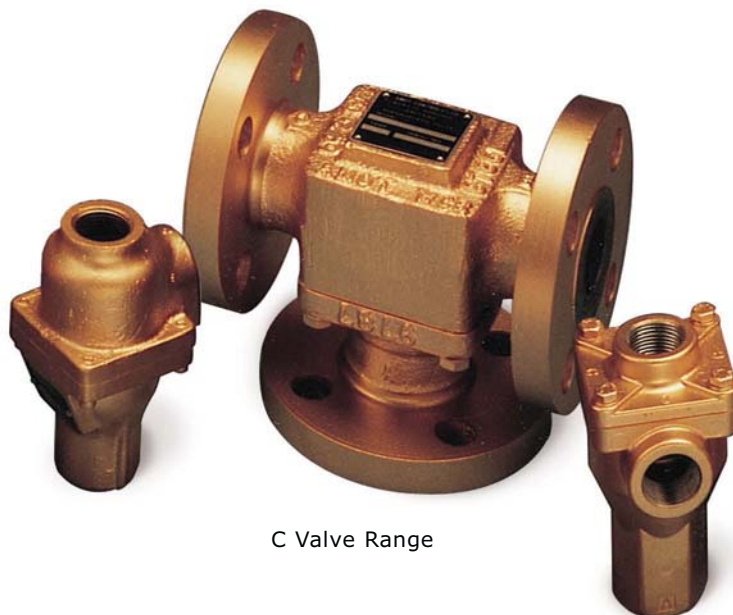

C Valve Range



Key benefits

- No external power source required - simple, low cost installation
- No user setting needed - 'fit and forget' solution
- Small number of parts - simple maintenance and low cost of ownership
- Robust design capable of high vibration and shock applications
- Easy installation, operates in any mounting position
- Automatic self-sensing control with positive proportional valve action

Key features

- Flow rates of 1.4 - 12m³/hr (6 - 54 US gpm)
- Combinations available: Housings in cast iron, aluminum, bronze, carbon steel, stainless steel
- DN15 - D40 (1/2" to 1 1/2") pipe sizes
- Threaded and flanged connections
- Tamper-proof temperature settings from 18°C to 113°C (65°F to 235°F)
- Pressure ratings up to 72 bar (1050 psi)

Accreditations available

- PED Suitable for Group 1 & 2 liquids (Ensure materials are compatible)
- ATEX  11 2 G X
-  Complies with all relevant EU directives

amot

www.amot.com

Datasheet_C_Thermostatic_Control_Valve_SEP15_Rev3

Thermostatic Control Valves - Model C

Contents

Overview	3
Applications	4
Valve Characteristics	4
Pressure drop	4
Flow coefficient	5
Temperature & element characteristics	7
Element type and seal material	7
How to order	6
Service kits	8
Specification	10
Weights	10
Dimensions	11

Thermostatic Control Valves - Model C

Overview

AMOT model C thermostatic valves are available in a wide selection of sizes and settings to fill a multitude of fluid temperature control requirements. These valves may be mounted in any position and use the proven expanding wax principle to actuate the 3-way temperature element assemblies. The model C valves may be used for diverting or mixing service. They make

very economical temperature limiting valves to prevent scalding in home, motel or hotel hot water supply systems. Radiant heating systems can use these valves in limiting water temperature to prevent surface cracking and over-heating of plastic piping. Other applications include electronic and battery cooling circuits, pump temperature relief valves etc.

Available housing materials

- Cast iron
- Aluminum
- Bronze
- Steel
- Stainless steel

Seal materials

- Buna-N/Nitrile
- Viton
- Neoprene

Element materials

- Bronze, brass and stainless steel
- Nickel plated/Stainless steel
- Stainless steel

Leak holes

In some applications, it is necessary to have leak holes drilled in the element to ensure a small flow between ports A and C. Leak holes are available in sizes ranging from 0.8mm to 6.3mm ($1/32''$ to $1/4''$). Please contact AMOT to determine the hole size required for specific applications.

Temperature settings

A wide selection of element materials, seals and temperatures are available. Follow the equipment manufacturers' guidelines for heating/cooling systems.

Temperature settings are available from 18°C to 113°C (65°F to 235°F). Refer to the Temperature & Element Characteristics table on page 6 for specific temperature settings. In general the temperature quoted is the nominal operating temperature in diverting mode on water systems.

For long life, AMOT valves should not be operated continuously at temperatures in excess of 14°C (25°F) of their maximum continuous rating. If this condition is anticipated then consult AMOT for suitable alternatives.

For mixing and oil circuits the temperature may be one to two degrees higher due to flow, viscosity and other system parameters.

Elements and seals are available in a variety of materials. These materials are suitable for most applications. Please contact AMOT for material compatibility information.

Thermostatic Control Valves - Model C

Applications

Diverting Applications

When valves are used for diverting service, the inlet is Port A (temperature sensing port), with Port C being connected to the cooler, and Port B connected to the cooler by-pass line.

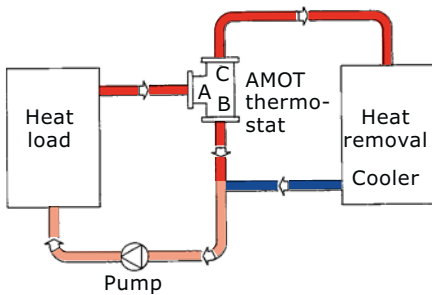

Mixing Applications

When valves are used for mixing service, Port C is the cold fluid inlet port from the cooler, Port B is the hot by-pass fluid inlet, and Port A the common outlet. Port A is the temperature sensing port and will mix the hot and cold fluids in the correct proportion so as to produce the desired outlet temperature leaving Port A.

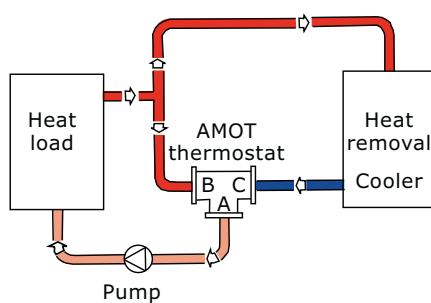

2-way Water Saving Applications

Valve as shown maintains minimum flow through cooler to conserve water. Requires internal leak hole to permit small flow for sensing.

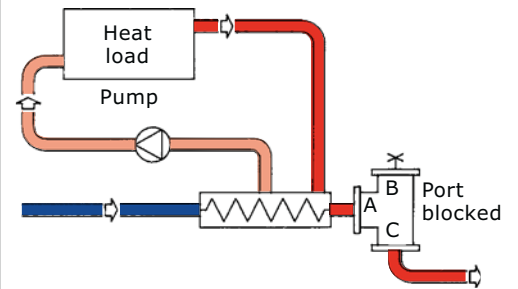

Valve characteristics

Pressure drop (Metric units)

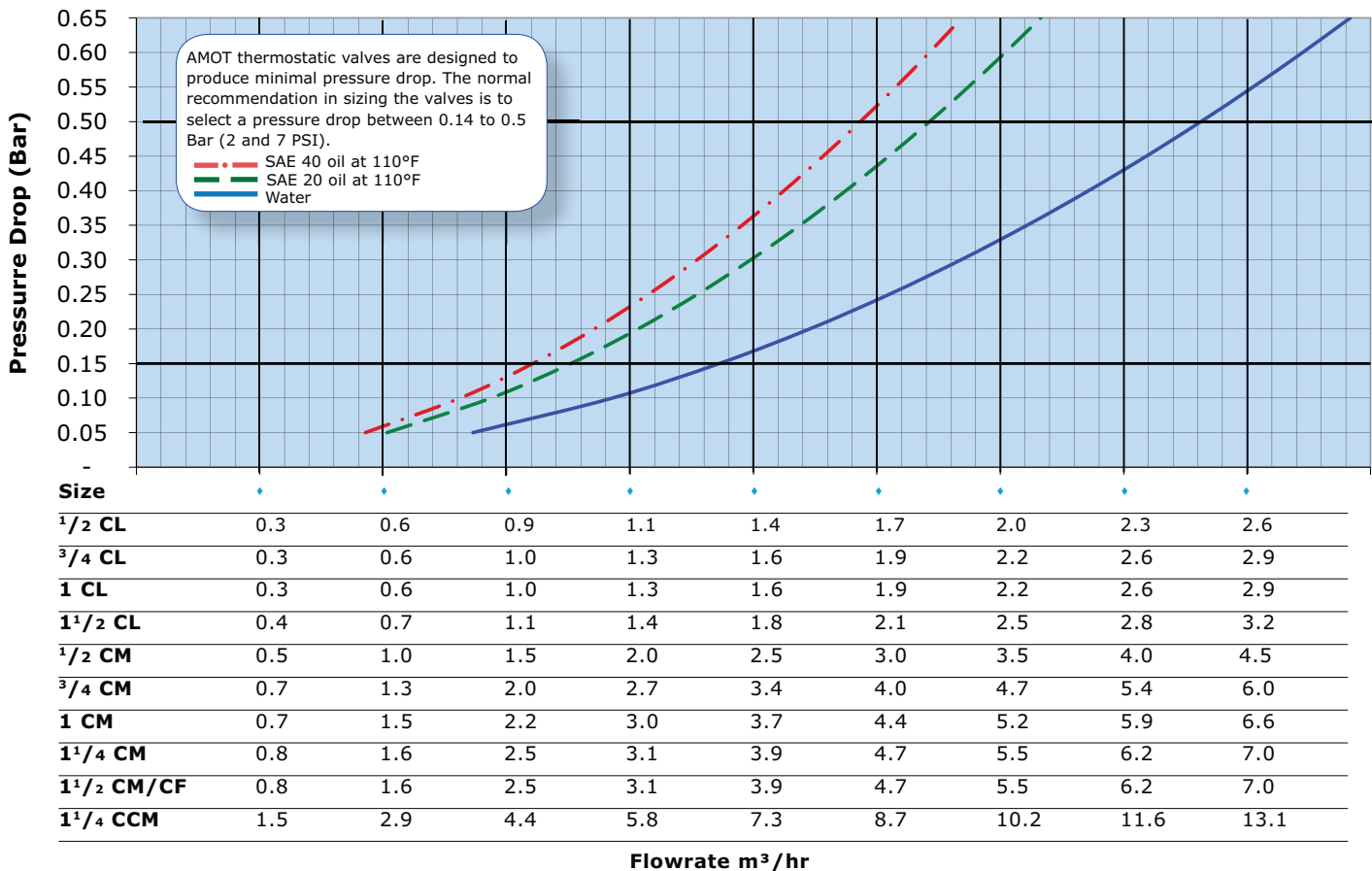

Thermostatic Control Valves - Model C

Valve characteristics

Pressure drop (English units)

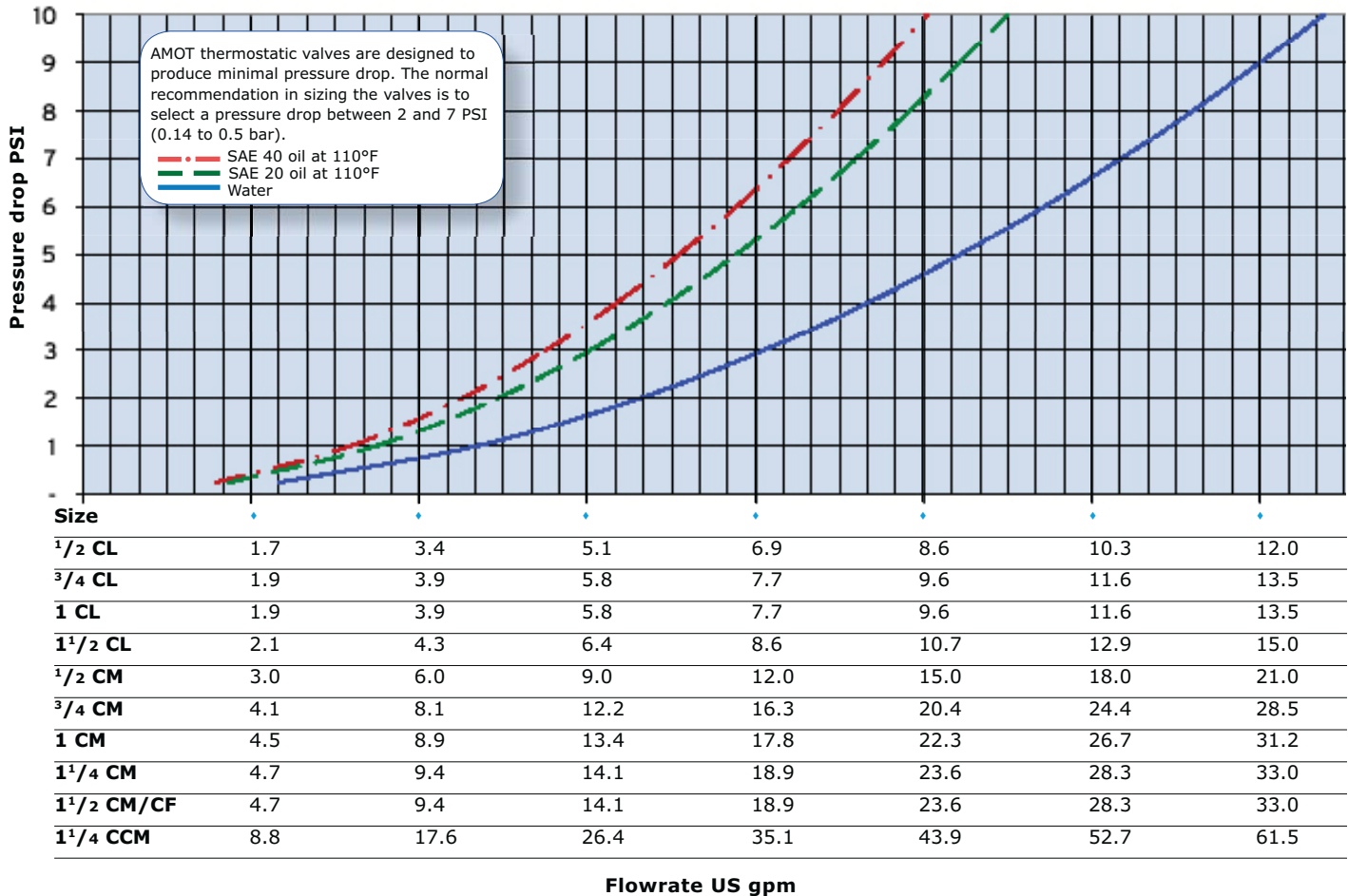

Flow coefficient

Flow coefficients (calculated)		
Size	Kv	Cv
1/2 CL	3.5	4.0
3/4 CL	3.9	4.5
1 1/2 CL	4.3	5.0
1/2 CM	6.1	7.0
3/4 CM	8.2	9.5
1 CM	9.0	10.4
1 1/4 CM	9.5	11
1 1/2 CM/CF	9.5	11
1 1/4 CCM	17.7	20.5

Kv is the flow coefficient in metric units. It is defined as the flow rate in cubic meters per hour (m³/h) of water at a temperature of 16° Celsius with a pressure drop across the valve of 1 bar. The basic formula to find a valve's Kv is shown below:

$$DP = \left(\frac{Q}{Kv}\right)^2 SG \quad Q = Kv \sqrt{\frac{DP}{SG}}$$

Q = Flow in m³/hr
 DP = Pressure drop (Bar)
 SG = Specific gravity of fluid (Water = 1.0)
 Kv = Valve flow coefficient

Cv is the flow coefficient in English units. It is defined as the flow rate in US Gallons per minute (gpm) of water at a temperature of 60° Fahrenheit with a pressure drop across the valve of 1 psi. The basic formula to find a valve's Cv is shown below:

$$DP = \left(\frac{Q}{Cv}\right)^2 SG \quad Q = Cv \sqrt{\frac{DP}{SG}}$$

Q = Flow in US gallons
 DP = Pressure drop (Psi)
 SG = Specific gravity of fluid (Water = 1.0)
 Cv = Valve flow coefficient

Thermostatic Control Valves - Model C

Valve characteristics continued

Available versions

Cast iron	Bronze	Aluminum	Steel	Stainless Steel
Threaded	Threaded	Threaded	Threaded	Threaded
1/2 CM/CL	1/2 CM/CL	3/4 CM/CL	3/4 CM/CL	3/4 CM/CL
3/4 CM/CL	3/4 CM/CL	1 CM/CL	1 CM/CL	1 CM/CL
1 CM/CL	1 CM/CL	Flanged	Flanged	Flanged
1 1/4 CCM	1 1/2 CM/CL	None	1 1/2 CF	1 1/2 CF
1 1/4 CM	Flanged		Welded	Welded
1 1/2 CM/CL	None		3/4" & 1" CM	3/4" & 1" CM
Flanged				
1 1/2 CF				

How to Order Valve

Use the tables below to select the unique specification of your G valve.

Example: **A B C D E F - G H - J**
Model 1 1/4 CCM C U 120 01 - F 1 - AA

A	Valve Size
	Nominal Bore Size
1/2	1/2 inch (DN15)
3/4	3/4 inch (DN20)
1	1 inch (DN25)
1 1/4	1 1/4 inch (DN32)
1 1/2	1 1/2 inch (DN40)

C	Body Material
B	Bronze (CM and CL)
C	Cast iron (CM, CCM, CF and CL)
A	Aluminum (CM, 3/4" and 1" only)
S	Steel (3/4" and 1" CM, 1 1/2" CF only)
R	Stainless steel (3/4" and 1" CM, 1 1/2" CF only)

B	Valve Model	
	Connections	No. of Elements
CM	Threaded valve	1
CCM	High flow valve (1 1/4" valve only)	2
CL	Low flow valve	1
CF	Flanged connection (1 1/2" valve only)	1

D	Port Connection
C	Flanged EN 1092, PN10, PN16
F	Flanged ANSI 125 lb
H	Flanged ANSI 300 lb (steel and stainless steel only)
J	Flanged 150 lb (steel and stainless steel only)
K	Flanged ANSI 600 lb (steel and stainless steel only)
M	Socket weld (1/4" & 1" steel & stainless steel CM valves)
T	Threaded NPT to USAS B2.1
U	Threaded BSP (PL) to BS 21
V	Threaded BSP (TR) Japanese (JIS)
W	Threaded to SAE J5 14H (straight thread, o-ring seal)
R	Threaded BSP (PL), boss faced, DIN 3852 Form X (Bronze, cast iron and ductile iron only)

Thermostatic Control Valves - Model C

How to Order Valve - continued

E	Control Temperature							
	Control temp.		Rated range				Max temp cont.	
	°C	°F	Crack open		Full open		°C	°F
			°C	°F	°C	°F		
065	18	65	15	59	25	77	47	116
075	23	75	20	68	29	85	60	140
085	30	85	24	75	34	93	63	145
095	35	95	30	86	40	104	73	163
100	38	100	33	91	42	108	61	143
110	43	110	38	100	47	117	82	180
120	49	120	43	110	55	131	86	187
130	54	130	49	120	60	140	95	203
140	60	140	54	130	65	150	95	203
150	65	150	60	140	71	160	100	212
160	71	160	65	150	76	170	100	212
170	76	170	72	163	82	180	100	212
175	80	175	76	170	85	185	105	221
180	82	180	79	175	88	190	110	230
190	87	190	85	185	93	200	110	230
200	93	200	90	194	100	212	110	230
205	96	205	93	200	103	218	110	230
215	101	215	96	205	107	225	115	239
225	107	225	101	214	114	237	120	248
235	113	235	107	225	133	253	124	257

G	Leakhole Sizes inches (mm)
B	1/32" (0.8)
C	1/16" (1.6)
D	3/32" (2.4)
F	1/8" (3.2)
G	1/4" (6.3)
H	3/16" (5)
0	None

H*	Leakhole Quantity (Number of elements w/leak hole, max. one per element)
0	None (Specified on CCM only)
1	1 (Specified on CCM only)
2	2 (Specified on CCM only)

*Note: Leakhole quantity (this field is not used for CM, CL, CF valves. CCM only).

J	Customer Special Code Assigned
-AA	Standard products
-***	Customer special code assigned

F	Element Type and Seal Material			
	Valve model	Element type	Element construction	Seals
01	CM/CCM/CF	1125X	Standard element	BunaN/ Nitrile
	CL	10765X		
06	CM/CCM/CF	1125X	Standard element	Viton
	CL	10765X		
99	CM/CCM/CF	3362U	Standard Element	Neoprene
	CL	10765U		
09	CM/CCM/CF	1125P	Nickel plated	BunaN/ Nitrile
	CL	10765P		
02	CM/CCM/CF	1125P	Nickel plated	Viton
	CL	10765P		
82	CM/CCM/CF	9778C	Nickel plated	Neoprene
	CL	10765K		
86	CM/CCM/CF	44844X	Salt water - SS	Viton

Thermostatic Control Valves - Model C

Service kits

Service Kit for Models CM/CL

Aluminum, steel or stainless steel housing

Replacement parts include:

- ⑤ Element
- ① Element O-ring seal
- ③ Housing O-ring seal
- ④ O-ring seal

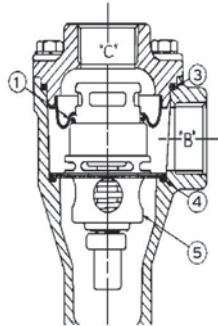

When properly applied and installed, AMOT thermostatic valves should operate for years with minimal maintenance. An inspection at two or three year intervals is adequate to detect and make provision for normal wear. The frequency of element replacement will depend on the operating conditions and the type of fluid being controlled. Because of the diaphragm and plug construction of the wax actuated element, calibration will be maintained over thousands of cycles.

Whenever elements are replaced, the O-ring seals should also be replaced. For convenience, elements and O-ring seals may be ordered together in the service kits listed here.

Service Kit for Models CM/CL

Cast iron or bronze housing

Replacement parts include:

- ⑤ Element
- ① Element O-ring seal
- ② Housing O-ring seal

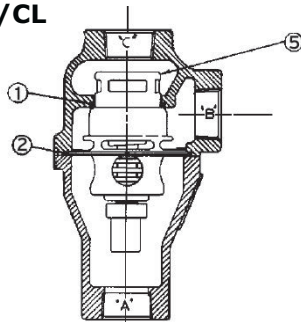

Service Kit for Models CCM

Cast iron housing

Requires two sets of parts

Replacement parts include:

- ⑤ 2 x Elements
- ① 2 x Element O-ring seals
- ② 2 x Housing O-ring seals

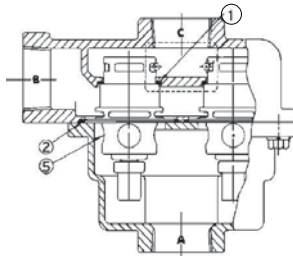

Service Kit for Models CF

Cast iron, steel or stainless steel housing

Replacement parts include:

- ⑤ Element
- ① Element O-ring seal
- ② Housing O-ring seal

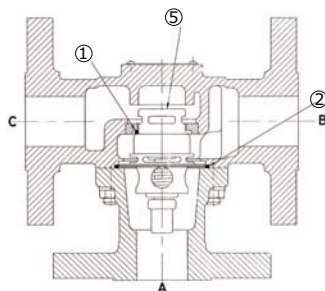

Thermostatic Control Valves - Model C

Service kits continued

Service kits are available with elements and seals required to service the valve. Order kits by part number and nominal temperature setting. If these are not known, refer to the model number

structure that is printed on the valve nameplate and on page 7. The element part number and temperature are also stamped onto the element flange.

Service kit model number structure

Sample codes

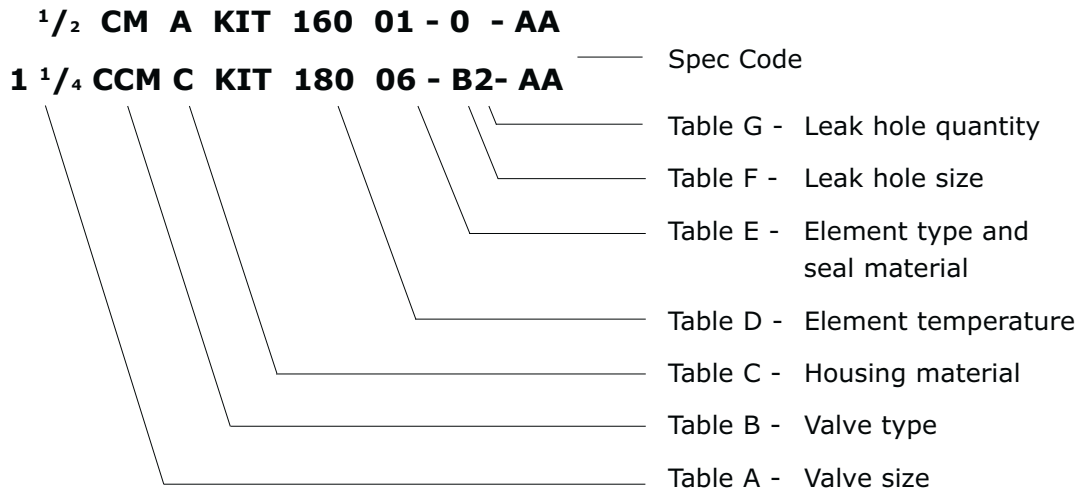

Table A	Table B	Table C	Table D	Table E			Table F		Table G (for CCM only)
Valve Size	Valve Type	Housing Material Code	Element Temp. Code	Code no.	Element Type	Seal Material	Leak Hole Code	Leak Hole Size	No. of elements with leak hole
1/2"	CM	A - aluminum	000*	01	Standard	Buna N	0	None	0
3/4"	CCM	B - bronze	065	06	Standard	Viton	B	1/32"	1
1"	CL	C - cast iron	075	99	Standard	Neoprene	C	1/16"	2
1 1/4"	CF	S - steel	085	09	Plated	Buna N	D	3/32"	
1 1/2"		R - stainless steel	095	02	Plated	Viton	F	1/8"	
			100	82	Plated	Neoprene	G	1/4"	
			110	86	Salt water	Viton	H	3/16"	
			120						
			130						
			140						
			150						
			160						
			170						
			180						
			190						
			200						
			215						
			225						
			235						

Note

*Kit provides seals only. No element is included.

Thermostatic Control Valves - Model C

Specification

Flow rate		1.4 - 12m ³ /hr	(6 - 54 gpm)
Body materials & pressure ratings	Cast iron	10 bar	(150 psi)
	Bronze	10 bar	(150 psi)
	Aluminum	24 bar	(350 psi)
	CS / SS Threaded	48 bar	(700 psi)
	CS / SS 150# Flanged	16 bar	(230 psi)
	CS / SS 300# Flanged	45 bar	(655 psi)
	CS / SS 600# Flanged	72 bar	(1050 psi)
Seal materials	Nitrile/Buna N, Viton, Neoprene		
Mounting position	Any orientation		
Ports	Below nominal temperature	Ports A and B connected	
	Above nominal temperature	Ports A and C connected	
Port connections	Threaded	15, 20, 25, 32 & 40 mm	(1/2", 3/4", 1", 1 1/4" & 1 1/2")
	Flanged	40 mm	(1 1/2")
Valve sizes (nominal bore)		15, 20, 25, 32 & 40 mm	(1/2", 3/4", 1", 1 1/4" & 1 1/2")
Recommended pressure drop		0.14 to 0.5 bar	(2 to 7 psi)
Control temperatures		18°C - 113°C	(65°F to 235°F)

Weight Weights in kg (lbs)

Material	1/2CM, CL 3/4CM, CL, 1CM, CL	3/4CMA, CL 1CMA, CL	3/4CMS, CL 1CMS, CL	1 1/4 CM 1 1/2 CM, 1 1/2 CL	1 1/4 CCM	1 1/2 CFCF	1 1/2 CFSJ 1 1/2 CFRJ	1 1/2 CFSH 1 1/2 CFRH	1 1/2 CFSK 1 1/2 CFSRK
Bronze	2 (4)	-	-	3 (6.6)	-	-	-	-	-
Cast iron	2 (4)	-	-	3 (6.6)	4.3 (9.5)	11 (24)	-	-	-
Stainless steel	-	-	3.6 (8)	-	-	-	9 (20)	13.5 (30)	16.3 (36)
Steel	-	-	3.6 (8)	-	-	-	9 (20)	13.5 (30)	16.3 (36)
Aluminum	-	1.2 (3)	-	-	-	-	-	-	-

Thermostatic Control Valves - Model C

Valve Dimensions

Model CM

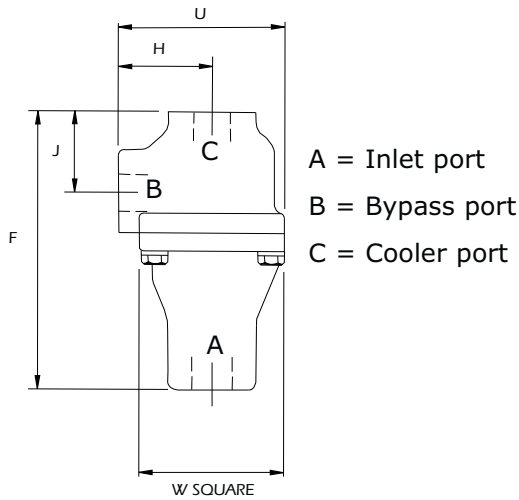

Model 1¹/₄ CCM

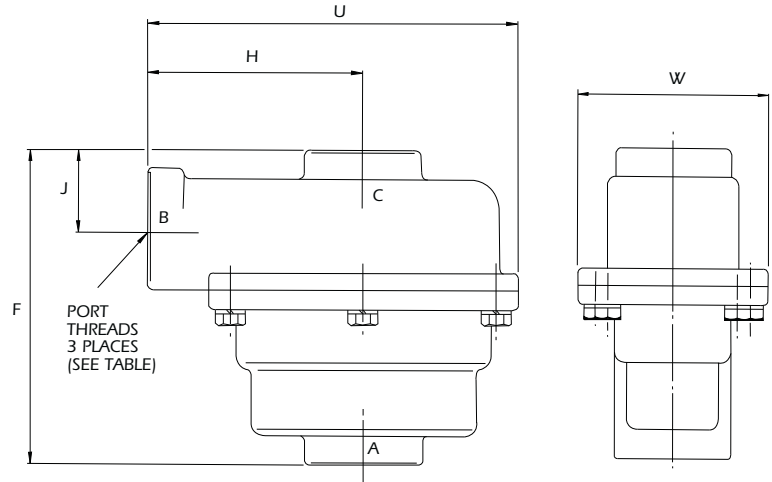

Valve Size and Type					
Threaded					
Dimension mm (inches)	1/2CMB, CMC, CLB, CLC 3/4CMB, CMC, CLB, CLC 1CMB, CMC, CLB, CLC	3/4CMA, CLA 1CMA, CLA	3/4CMR, CMS, CLR, CLS 1CMR, CMS, CLR, CLS	1 ¹ / ₂ CM 1 ¹ / ₂ CM, CL	1 ¹ / ₄ CCM
H	50.8 (2)	54 (2.1)	54 (2.1)	73 (2.9)	111 (4.4)
J	44.5 (1.78)	54 (2.1)	54 (2.1)	38.1 (1.5)	39.7 (1.6)
F	152.4 (6.10)	160.3 (6.4)	160.3 (6.4)	158.8 (6.3)	155.6 (6.2)
U	90.5 (3.62)	95.3 (3.8)	95.3 (3.8)	115.9 (4.6)	190.5 (7.6)
W	79.4 (3.18)	82.6 (3.3)	85.7 (3.4)	85.7 (3.4)	98.4 (3.9)

Model 1¹/₂ CF

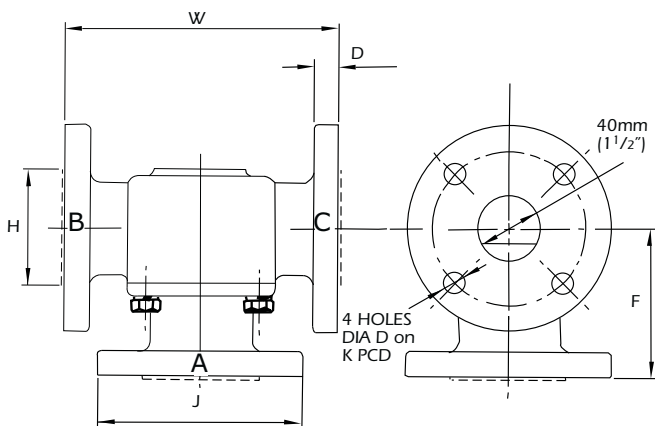

Flange Sizing mm (inches)		
Flange	D	K
ANSI 125 lb	16 (1/2)	98.43 (4)
ANSI 150 lb	16 (1/2)	98.43 (4)
ANSI 300 lb	22 (3/4)	114.3 (4 1/2)
ANSI 600 lb	22.2 (7/8)	114.3 (4 1/2)

Valve Size and Type (Flanged)				
Dimension mm (inches)	1 ¹ / ₂ CFCF	1 ¹ / ₂ CFSJ 1 ¹ / ₂ CFRJ	1 ¹ / ₂ CFSH 1 ¹ / ₂ CFRH	1 ¹ / ₂ CFSK 1 ¹ / ₂ CFSRK
H	-	73 (2.9)	73 (2.9)	73 (2.9)
J	150 (6)	127 (5)	156 (6.2)	156 (6.2)
F	100.8 (4)	100.8 (4)	120.6 (4.8)	130 (5.1)
W	178 (7)	178 (7)	203.2 (8)	223 (8.75)