



Moisture Separators

- ▶ 99% EFFICIENT
Unlike most moisture separators this unique design is efficient over a wide range of air flows.
- ▶ LIGHT WEIGHT
Aluminum Construction.
Reduces stresses to piping
- ▶ LOW PRESSURE DROP
Very low differential pressure.



BULLETIN MSB-2

Moisture Separators

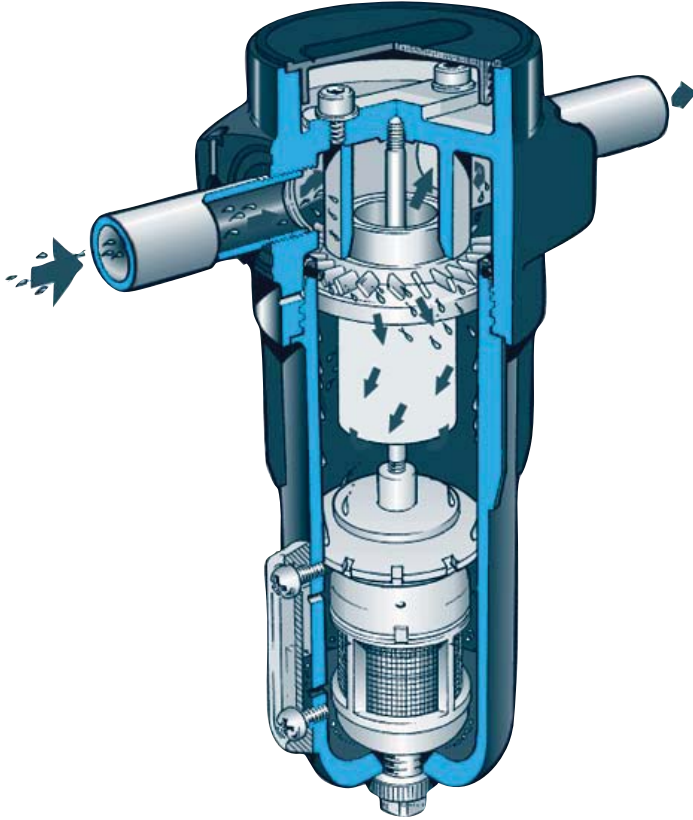

Aftercoolers and Moisture Separators work hand-in-hand to cool and remove damaging water from compressed air systems.

Aftercoolers are designed to cool compressed air, condensing the moisture in the air stream.

Moisture Separators remove the condensed water from the system.

The Aftercooler is only as effective as it's moisture separator.

AKG Thermal Systems Moisture Separators are more efficient than traditional designs. In fact, they will maintain 98% efficiency all the way down to 50% of the rated flow capacity!

NOT JUST INEXPENSIVE — EFFICIENT AS WELL!

Performance

MODEL	SCFM FLOW CAPACITY		
	MINIMUM	NOMINAL	MAXIMUM
MS 85C	65	85	105
MS 300D	225	300	375
MS 300E	225	300	375
MS 300G	225	300	375
MS 750H	525	750	925
MS 1700I	1270	1700	2100
MS 1700J	1270	1700	2100

- Pressure drop is 1.0 PSI at nominal flow.

PRESSURE DROP CORRECTION FACTOR						
LINE PRESSURE	15	45	75	100	150	200
CAPACITY CORRECTION FACTOR	0.25	0.5	0.8	1.0	1.2	1.4

- To obtain flow capacities at various line pressures, multiply the SCFM flow capacity by the correction factor above.

Dimensions

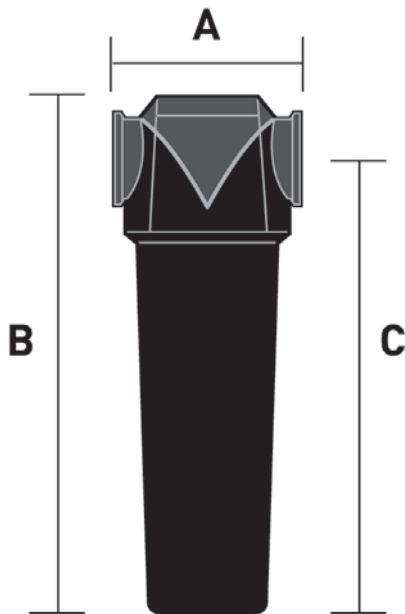

MODEL	PIPE SIZE	A	B	C	WEIGHTS (LBS)
MS 85C	½" NPT	3.8	9.3	7.9	3
MS 300D	¾" NPT	5.1	10.8	9.2	7
MS 300E	1" NPT				
MS 300G	1½" NPT				
MS 750H	2" NPT	6.7	17	15	15
MS 1700I	2½" NPT	8.1	19.9	17.5	25
MS 1700J	3" NPT				

- Dimensions are in inches.
- We reserve the right to make reasonable design changes without notice.

Specifications

RATINGS

MAXIMUM WORKING PRESSURE.....	250 PSI
MAXIMUM WORKING TEMPERATURE.....	150 °F
MINIMUM RECOMMENDED TEMPERATURE.....	35 °F

Ordering Information

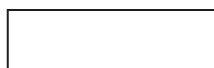

MS SERIES

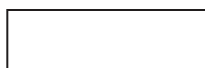

**MODEL SIZE
SELECTED**



DRAIN OPTION
BLANK = FLOAT TYPE DRAIN
ND = MANUAL TYPE DRAIN

AKG Worldwide

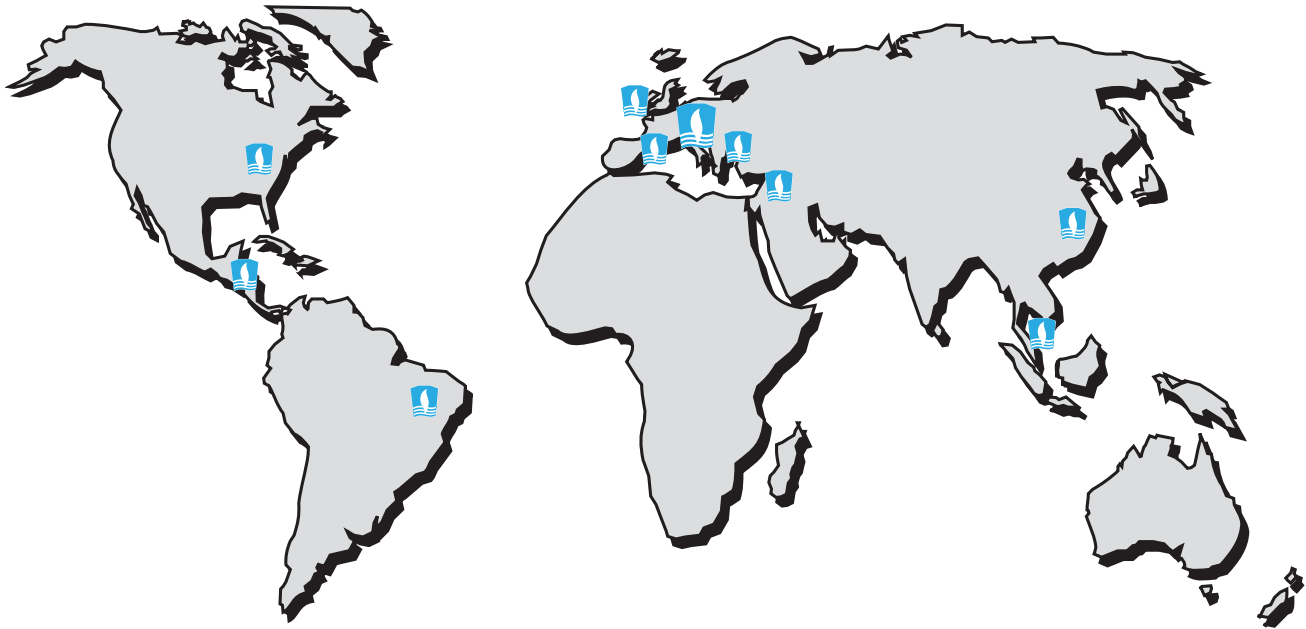

AKG has been manufacturing high quality coolers and cooling systems since 1919. We have grown to include 10 facilities with over 1400 employees to serve you.

Your Business Partner



AKG Worldwide

AKG is a complete single source supply for all of your cooling requirements. Choose from both standard and custom engineered products depending on your specific needs.



Partnership

AKG believes in solid long-term business relationships built on partnerships with its customers.



Customer

AKG places heavy emphasis on development of leading edge technologies, products and finding creative solutions to our customers individual requirements.